



Owner's Manual

Sage L75
Bi-amplified Floor-Standing Line Source
Coaxial Planar Magnetic Loudspeaker

Table of Contents

Introduction.....	3
Overview.....	4-7
Unpacking & Installation.....	7-8
Connections.....	9-10
Care & Maintenance	10
North American Warranty.....	11
Obtaining Service.....	12
Specifications.....	13
Dimensions.....	14

DOCUMENT CONVENTIONS

This document contains general safety, installation and operation instructions for the Wisdom Audio Sage L75 loudspeakers. It is important to read this document before attempting to use this product. Pay particular attention to:

WARNING: Calls attention to a procedure, practice, condition or the like that, if not correctly performed or adhered to, could result in injury or death.

CAUTION: Calls attention to a procedure, practice, condition or the like that, if not correctly performed or adhered to, could result in damage to or destruction of part of or the entire product.

Note: Calls attention to information that aids in the installation or operation of the product.

Introduction

Congratulations on purchasing your Wisdom Audio system. It incorporates many design features designed to give you decades of pleasure and performance. Many of these design choices are uncommon among loudspeaker manufacturers, and bear some explanation. See the following section entitled “Overview” for more information.

Our unique driver designs and our emphasis on achieving real-world performance account for the “system” approach taken. These are not speakers that are simply connected to speaker wires and promptly forgotten. We recognize that setting up a Wisdom Audio system is a bit more involved than connecting a common set of loudspeakers, which is why we insist that our dealers perform the installation and calibration of the systems. We know that the extra effort (particularly as regards setting up the SC-2 and SC-3 System Controller) yields vastly improved results.

This manual focuses on the loudspeakers themselves. In order to fully understand the system, we recommend you also review the manual for the SC-2/SC-3 System Controller, without which these speakers will not perform correctly.

While we expect your local Wisdom Audio dealer to take care of the setup and calibration of the system, we still recommend that you at least briefly review this and the other manuals (SC-2/SC-3, RTL subwoofers) to understand the system’s full capabilities.

Your Sage L75 loudspeakers are specifically designed to avoid the compromises inherent in conventional speaker designs. The active crossover and room correction circuitry in the SC-2 & SC-3 is essential to the speakers’ proper operation. It is truly a “system” design, and not merely a collection of loudspeaker drivers in a box.

Overview

Your Sage L75 loudspeakers take advantage of several critical technologies to deliver a level of performance that has never been available in a loudspeaker that intruded so modestly on your living space. In fact, this level of performance has rarely been attained, regardless of the space and budget at one's disposal.

Since several of these technologies cannot readily be found elsewhere, we will take the time to describe them in more detail than would be necessary for more conventional designs.

Our planar magnetic drivers use an advanced, thin film membrane to move the air. This film can respond instantly to the smallest detail in the signal. It has vastly less inertia than traditional "cone & dome" drivers, so the signal is never blurred in any way.

One of the most remarkable things about the sound of well-designed planar magnetic speakers is their lack of thermal or dynamic compression. There are several reasons for this:

- The lightweight diaphragm responds quickly to even the smallest signals, yet is robust enough to handle a great deal of power.
- The voice coil is laid out flat and is exposed to the air on both sides; the large resulting surface area dissipates heat extremely quickly and efficiently.
- Since heat does not build up in the voice coil (as it does in conventional dynamic drivers), the load seen by the amplifier does not change at high power levels.

When you become accustomed to the sound of your new Sage L75 speakers, conventional speakers sound a bit bland and lifeless. You may also discover yourself hearing details at even modest levels on the L75 that were previously inaudible even at loud volumes on more conventional speakers.

The "voice coil" in the planar magnetic driver is spread out over a large, flat area that is exposed to the open air. As such, when a huge transient comes along, any heat that is generated is immediately dissipated. This compares quite favorably to other designs in which the voice coil is buried inside a massive piece of metal, where the heat has effectively no place to go.

The excellent heat dissipation of these drivers makes them remarkably reliable. Planar magnetic speakers can handle a great deal of power without undue stress or audible strain. In fact, for a given size, they can handle *many times* the power of a traditional dynamic driver.

Overview *(continued)*

Because the conductor of a planar magnetic driver is essentially a long, thin wire, it presents a purely resistive load to the amplifier. This is comparable to the simple test loads that amplifier companies use when measuring their amplifiers to show how terrific they are. As such, you can be assured that your amplifiers will sound and work their best.

Authoritative, deep bass requires that you move a lot of air. We have chosen to use dynamic woofers for the bass because they can provide excellent performance at lower frequencies.

In order to get comparable bass performance from a planar magnetic design, you would need to have a huge speaker that would be impractical in most domestic living spaces. It simply makes more sense to use the best transducer technology in each area of the reproduced spectrum. One of Wisdom Audio's strengths is in seamlessly blending these technologies — particularly important given the high standards set by our planar magnetic drivers.

Of course, the dynamic woofers themselves must be rather extraordinary in order to “keep up” with the planar magnetic drivers right up to the crossover frequency.

Our woofers are different because they must be in order to do their job. Specifically, we need highly dynamic, uncompressed bass (to keep up with the planar magnetic drivers) that does not depend on a critical amount of enclosure volume (since these speakers are mounted in your wall, and use the space inside the wall as their “enclosure”). These two design goals require rather extraordinary attention to myriad details.

The motor and suspension system of these woofers therefore includes all the critical damping required for optimal operation. (In most speakers, the woofers depend on the air trapped inside their enclosures as an additional “spring” to help them behave properly.) Technically, this approach is known as an “infinite baffle” design. In practice, the volume of air behind the speaker does not have to be infinite, of course. It just needs to be large enough to not act like an acoustic “spring”. Recommended and minimum enclosure volumes for the speaker are listed in the Specifications section, and repeated on the Dimensions page.

Many speakers include a mid-bass “bump” in their response to give the illusion of going deeper in the bass than they actually do. Unfortunately, this “bump” makes blending them seamlessly with a high quality subwoofer almost impossible.

All Sage Series speakers have been designed for optimally at response to 80 Hz, which is the most-common crossover frequency used with subwoofers.

Line Source Speakers

Almost all loudspeakers radiate sound into the room as imperfect “point sources”. This means that most of the energy they put into the room expands as an ever-enlarging sphere, as though emerging from a single point in space. This results in a multitude of reflections from the ceiling and floor that can degrade sound quality.

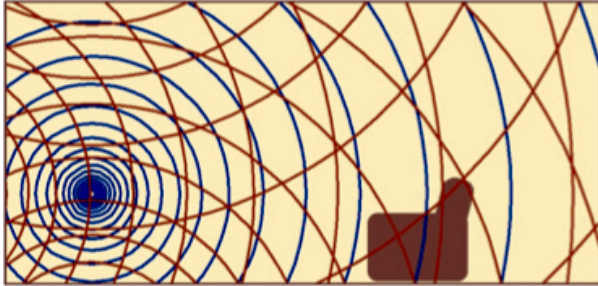

By contrast, the Sage L75 speakers radiate sound as a “line source”. The sound moves into the room as an expanding cylinder, rather than as an expanding sphere — as though from a vertical line suspended in space.

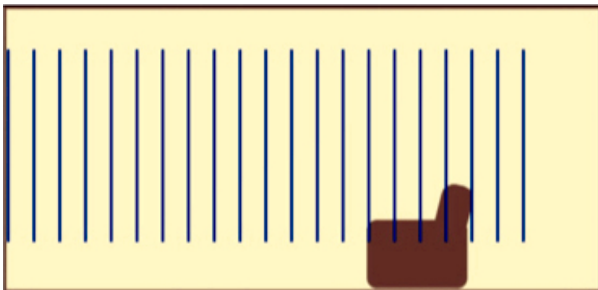

Line source speakers provide two significant advantages:

- Ceiling and floor reflections are minimized, resulting in greatly reduced interference, letting you hear more of the speaker and less of the room;
- The sound pressure level (SPL) throughout the room is much more evenly distributed, making it much easier to set the “right” volume, no matter where the audience is seated.

To achieve this highly desirable line source behavior, it is essential to have a tall and slim driver. (Simply stacking multiple “cone & dome” high frequency drivers does not create a proper line source. Instead, it creates a *series* of point sources, which end up interfering with each other). With Wisdom Audio’s planar magnetic technology, it becomes possible to have drivers that are *extremely* tall and slim.

Because of this shape, the sound (even at high frequencies) is distributed uniformly across the width of the room from a driver that “looks” only less than an inch wide

acoustically. However, the sound is launched in a much more directional way vertically. By minimizing early reflections from the ceiling and the floor, the clarity of the system is greatly enhanced. This is heard in both tremendous musical detail and in much-improved dialog intelligibility.

For more detailed information on planar magnetic drivers and the difference between point source and line source speakers please visit www.wisdomaudio.com.

Unpacking & Installing the L75

The Wisdom Audio Sage L75 freestanding speaker is a substantial piece of equipment. Please exercise caution when unpacking your L75 to ensure that you do not strain yourself from its (perhaps unexpected) weight.

CAUTION: Do not attempt to lift your L75 by yourself. Unpacking these speakers is easy for two people, but it is unwise for a single person to attempt doing so. Do not attempt to lift your L75 while bending or twisting from the waist. Use your legs for lifting, not your back. Always stand as straight as possible and keep the L75 close to your body to reduce strain on your back.

Your L75 is packed for shipping in two distinct boxes.

The speaker itself is in a “telescoping” box (two five-sided boxes, one of which fits snugly inside the other). Gently roll the box over so that its bottom is facing up. Then carefully cut the tape along the bottom of the box on all four sides. Roll the box over again so the bottom is on the floor, and lift off the top. With one person at each end, carefully lift the speaker out of the box and lay it on a soft surface (carpet or similar).

Attaching the bases - The bases for a pair of speakers are packed separately in a flat box. Using the supplied Allen wrench, attach them to the speaker using the four bolts found in the riser at the bottom of the speaker tower. These bolts should be snug - do not over-tighten. You will feel when firm, metal-to-metal contact is made. Do not tighten more than 1/8” of a turn beyond the point of initial, snug metal to-metal contact.

We do not recommend removing the grille on your new loudspeakers. The grille is an integral part of the design; moreover, the planar magnetic film should never be touched, as it is tensioned precisely at the factory. The grille plays an important protective role as well as an aesthetic one.

After unpacking your L75, keep all packing materials for future transport. In the event that you need to ship your L75, only the original, purpose-designed shipping carton is acceptable. Any other method of shipping this product runs a significant risk of damage to the L75 - damage that would not be covered by the warranty. (If you lose your packaging and need to ship your speakers, replacement packaging can be purchased from Wisdom Audio.)

When to install spikes - The floor-standing versions of the Wisdom Audio Sage Series speakers are supplied with adjustable “spikes” for both leveling the speaker and securely coupling it to the floor. The spikes are shipped with the blunt end exposed. We recommend experimenting with room placement while the spikes are in this position. The pointed ends are quite sharp and may scratch the floor, or get caught on the carpet.



Wisdom Audio spikes are reversible for use on either hard or carpeted floors. The sharp end of the spike is designed to penetrate the carpeting and couple to the floor beneath, for excellent stability and improved sound. When on tile or hardwood floors, however, use the blunt end of the spike instead to avoid floor damage. In either case, you can adjust the height of the individual spikes to compensate for slightly uneven floors. When this fine adjustment has been made, tighten the large black nut snugly against the bottom of the base to prevent them from further movement.

Note - If you fail to tighten the black nuts that secure the spikes, they may rattle a bit when playing music or movies. This rattling can sound like speaker distortion. Fortunately, a quick tightening of the lock nuts on the spikes will eliminate the problem.

After you have determined the final locations of the L75 speakers, enlist the assistance of a friend to safely tip the speaker to provide better access to the adjustable spikes to maximize stability (even with uneven floors). Tilting it even as little as 15°-20° provides access to the threaded holes for the spikes without straining your helper. Reverse the spikes if you are on a carpeted floor. Once the first two spikes are securely in place, switch sides and repeat the process on the other side. Fine-tune things until the speaker is both solidly stable and plumb.

Making the L75 Connections

As with any system, you should make changes to the connections only when the power is turned off to avoid any chance of inadvertently causing a problem (such as a short-circuit).

Two sets of speaker wires are required for each Sage L75 loudspeaker: one for the woofer (low pass) section, and a separate one for the planar magnetic (high pass) section that handles the midrange and treble.

We recommend using heavy-gauge speaker wire, the gauge will vary dependent on your speaker run length. Please consult an authorized dealer to determine what gauge would be best for your application.

For the purposes of this manual, we will assume that you have already connected the SC-2/3 System Controller as per the instructions found in its manual. As such, you should have signal coming from your source component(s) to a preamp/processor, and then on to the SC-2/3; following the SC-2/3, the signal is split into low and high sections, with the low section going to one or more Wisdom Audio SA Series amplifiers, and the high section going to another amplifier, which will drive the planar magnetic panels.

We strongly recommend using spade, hook or ring lugs to terminate the speaker wires whenever they are connected to the patented Cardas connectors, an example of which is shown below. Wisdom Audio uses these connectors on both our power amplifiers and on our freestanding loudspeakers



Connect the outputs of your Wisdom Audio SA-series amplifier to the appropriate woofer sections, taking care to get both the channel assignments and the polarity correct. Connect the positive (+) terminals on the SA Series amplifier to the positive (+) terminals for the woofer on the loudspeaker; likewise, connect the negative (-) terminals on the amplifier and the speaker, respectively.

Next connect the outputs of your chosen amplifier for the midrange/treble to the Sage L75 planar sections in a similar fashion, taking care with both channel assignments and polarity.

Care & Maintenance

To remove dust from the front of your L75, use a feather duster or a lint-free soft cloth.

Never attempt to clean the drivers themselves.

Caution!

Do not touch the surface of the planar magnetic drivers, under any circumstances. The thin film has been carefully pre-tensioned at the factory; any subsequent contact can only damage it.

North American Warranty

Standard Warranty

When purchased from and installed by an authorized Wisdom Audio dealer, Wisdom Audio loudspeakers are warranted to be free from defects in material and workmanship under normal use for a period of ten years from the original date of purchase.

Furthermore, the transducers (“drivers”) in your Wisdom Audio speakers are warranted to be free from defects in material and workmanship under normal use for a period of ten years from the original date of purchase.

Harsh Conditions Use

Wisdom Audio loudspeakers are designed for installation and operation in environmentally controlled conditions, such as are found in normal residential environments. When used in harsh conditions such as outdoors or in marine applications, the warranty is three years from the original date of purchase.

During the warranty period, any Wisdom Audio products exhibiting defects in materials and/or workmanship will be repaired or replaced, at our option, without charge for either parts or labor, at our factory. The warranty will not apply to any Wisdom Audio products that has been misused, abused, altered, or installed and calibrated by anyone other than an authorized Wisdom Audio dealer.

Any Wisdom Audio product not performing satisfactorily may be returned to the factory for evaluation. Return authorization must first be obtained by either calling or writing the factory prior to shipping the component. The factory will pay for return shipping charges only in the event that the component is found to be defective as mentioned above. There are other stipulations that may apply to shipping charges.

There is no other express warranty on Wisdom Audio products. Neither this warranty nor any other warranty, express or implied, including any implied warranties of merchantability or fitness, shall extend beyond the warranty period. No responsibility is assumed for any incidental or consequential damages. Some states do not allow limitations on how long an implied warranty lasts and other states do not allow the exclusion or limitation of incidental or consequential damages, so the above limitation or exclusion may not apply to you.

This warranty gives you specific legal rights, and you may also have other rights, which vary from state to state. This warranty is applicable in the United States and Canada only. Outside of the U.S. and Canada, please contact your local, authorized Wisdom Audio distributor for warranty and service information.

Obtaining Service

We take great pride in our dealers. Experience, dedication, and integrity make these professionals ideally suited to assist with our customers' service needs.

If your Wisdom Audio loudspeaker must be serviced, please contact your dealer. Your dealer will then decide whether the problem can be remedied locally, or whether to contact Wisdom Audio for further service information or parts, or to obtain a Return Authorization. The Wisdom Audio Service Department works closely with your dealer to solve your service needs expediently.

IMPORTANT: Return authorization must be obtained from Wisdom Audio's Service Department BEFORE a unit is shipped for service.

It is extremely important that information about a problem be explicit and complete. A specific, comprehensive description of the problem helps your dealer and the Wisdom Audio Service Department locate and repair the difficulty as quickly as possible.

A copy of the original bill of sale will serve to verify warranty status. Please include it with the unit when it is brought in for warranty service.

WARNING: All returned units must be packaged in their original packaging, and the proper return authorization numbers must be marked on the outer carton for identification. Shipping the unit in improper packaging may void the warranty, as Wisdom Audio cannot be responsible for the resulting shipping damage.

Your dealer can order a new set of shipping materials for you if you need to ship your loudspeaker and no longer have the original materials. There will be a charge for this service. We strongly recommend saving all packing materials in case you need to ship your unit some day.

If the packaging to protect the unit is, in our opinion or that of our dealer, inadequate to protect the unit, we reserve the right to repackage it for return shipment at the owner's expense. Neither Wisdom Audio nor your dealer can be responsible for shipping damage due to improper (that is, non-original) packaging.

Specifications

All specifications are subject to change at any time, in order to improve the product.

- **Number of required amplifier channels:** 2
- **Frequency response:** 40Hz – 20 kHz \pm 2dB relative to the target curve
- **Impedance, planar section:** 4.5 Ω
- **Impedance, woofer section:** 3 Ω
- **Sensitivity, planar section:** 95 dB/2.83V/1m
- **Sensitivity, woofer section:** 91 dB/2.83V/1m
- **System impedance:** 3.8 Ω
- **System sensitivity:** 93 dB
- **Power handling, continuous:** 200w
- **Dimensions:** see appropriate dimensions drawings on next page
- **Shipping weight, each L75:** 79 lbs. (36 kg)
- **Shipping weight, pair of L75 bases:** 30 lbs. (14 kg)

For more information, see your Wisdom Audio dealer, or contact:

Wisdom Audio
1572 College Parkway, Suite 164
Carson City, NV 89706
www.wisdomaudio.com
information@wisdomaudio.com
Ph: 775.887.8850

L75 Dimensions

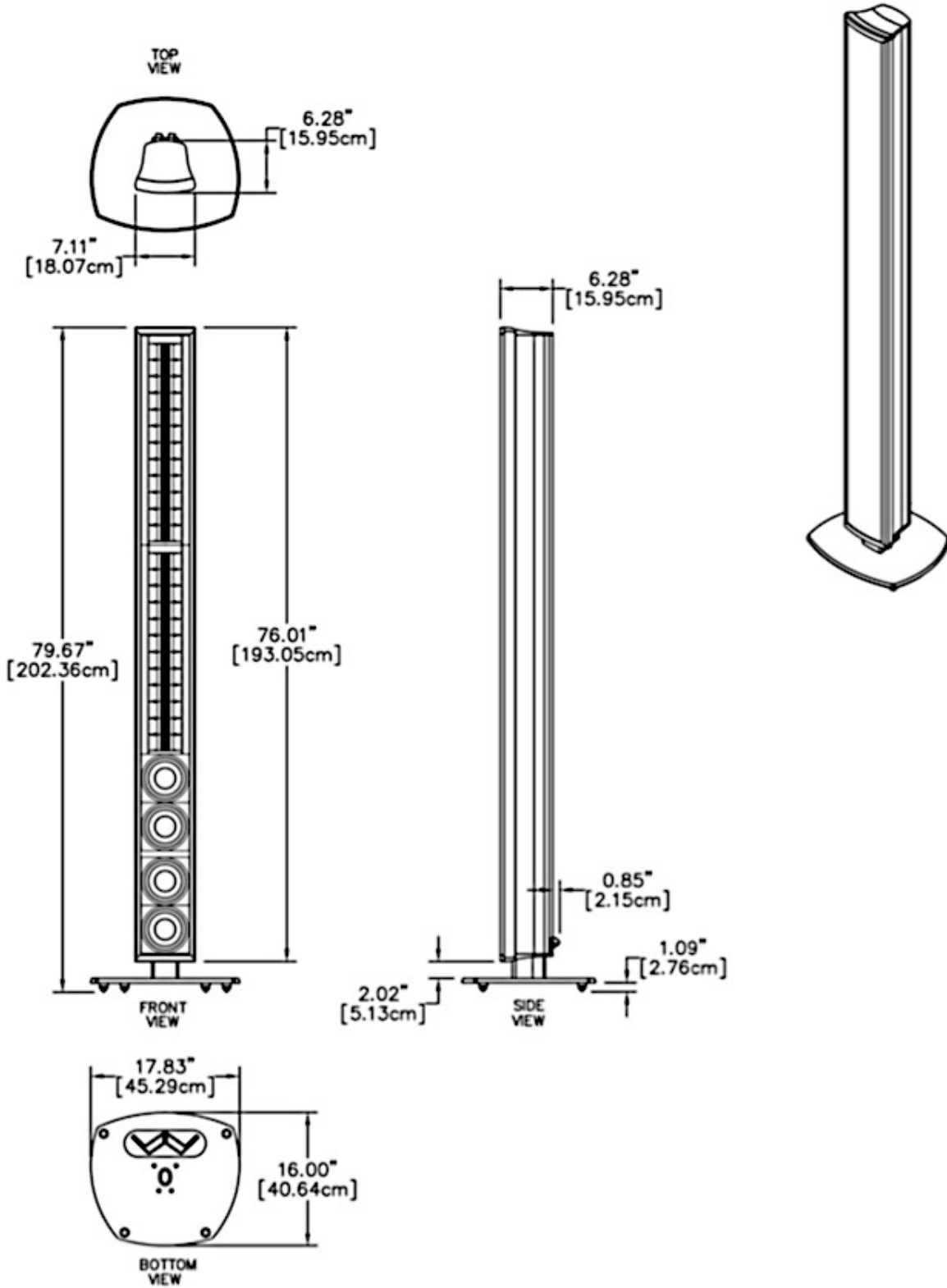



W I S D O M[®]

WISDOM and the stylized W are registered trademarks of Wisdom Audio.

Wisdom Audio 1572 College Parkway, Suite 164
Carson City, Nevada 89706 USA
Telephone: 775.887.8850
Fax: 775.887.8820
www.wisdomaudio.com