



Wisdom Audio

Planar Magnetic Technology

Planar Magnetic Technology

Overview

There are hundreds of companies building loudspeakers in the world today, yet you can count the number of fundamental driver technologies they are using on one hand. Why is this the case? Are there loudspeaker technologies available that might solve modern-day problems more ably than decades-old “traditional” approaches do?

This paper will provide a brief overview of the requirements of any loudspeaker driver, along with some historical perspective on why we see the solutions we do today. We will then take a closer look at one of the less common technologies (planar magnetics) and why it presents some unique advantages when implemented correctly. We will also look at the limitations of planar magnetic drivers, and at what might be done to address them.

Finally, we will turn to the specifics of Wisdom Audio planar magnetic technology

The task at hand

The sounds we hear exist as complex vibrations in the air around us. Our ears are tremendously sensitive instruments, capable of distinguishing subtle differences in the spectrum and the timing of those vibrations.

There is good reason for these abilities of ours. Imagine an ancestor hunting game in the forest: the “weight” of a crunching sound might tell him whether the animal that made it was small or large; depending on when the sounds hit his two ears, he could tell the direction from which it came. You can imagine that the sound of a bear coming up behind them might trigger a different response than that of a squirrel... or else his descendants might not be here to discuss it today.

In a more modern context, we would never mistake the sound of a flute for the sound of a violin, even when they play the same note. This is because each is creating a series of related vibrations rather than a single, pure vibration, and the proportion and timing of these additional frequencies creates the distinctive character of a flute, or a violin, or even the difference between a Martin guitar and a Gibson guitar. In fact, everything that vibrates tends to favor certain



frequencies over others — this is called *resonance* — and the particular resonances of musical instruments determine whether they are fine instruments or mediocre ones.

A loudspeaker — any loudspeaker — has a significantly different job to do. Ideally, it would reproduce all frequencies equally well, showing no favor whatsoever for one versus another. It would not suffer from inertia, nor be limited in any practical way as to the amount of air it can move. In fact, a list of characteristics of an ideal loudspeaker “driver” (the part that actually moves by design, in response to the signal being supplied) might be as follows:

- **Fairly Large**—to be able to move all that air
- **Weightless (no mass)**—so it could start and stop on a dime, as dictated by the needs of the music
- **Perfectly Rigid**—so that it would not flex, which would distort its motion and thus the resulting sound
- **Perfectly Non-Resonant**—so it would not add its own colorations to the sound
- **Extremely Sensitive**—so your amplifier would not run the risk of running out of power during peak demand
- **Extremely Rugged**—so you would not have to worry about getting rowdy
- **Capable of Large Excursions**—so you could move all that air *a lot* (for high volumes when rowdy)
- **Predictable, Uniform Dispersion**—so the speakers would sound the same from a wide variety of seating positions, and interact more predictably with the room in which they found themselves
- **A Simple Impedance**—so any amplifier could work well with it, and sound its best

As you can see, imagining anything which has all of these characteristics at the same time is quite challenging. How is something going to be both physically large, and yet virtually weightless? And if you manage that, will it also be rigid enough not to flex and distort the sound? And how rugged would it be when it came time to playing movies or music at realistic volumes?

Some history...

The history of driver design is one of trading off one set of desirable characteristics against another, trying to find the best possible compromise. The fact that driver design continues to be so challenging is a testimony to the difficulty of the task itself.

The basic technologies used in virtually all loudspeaker drivers today have existed since the 1920's and even earlier. The main improvements have been in execution details (*materials technology, better magnets, modern adhesives, and the like*) rather than in the fundamentals of what is being attempted.

We'll take a quick look at the more successful approaches.

Dynamic drivers

Perhaps 99% of all loudspeakers use dynamic drivers to vibrate the air and thereby create sound. You are undoubtedly familiar with them on some level, so we will review only the barest details here.

Dynamic drivers take advantage of the fact that running an electrical current through a wire induces a magnetic field. If you suspend the wire in another magnetic field, the two fields interact, creating a force that tries to move one relative to the other. Dynamic drivers wrap the wire into a coil, and suspend this coil inside a circular magnet, so as to get more wire in close proximity to a strong magnetic field. This approach results in the creation of a relatively strong force.

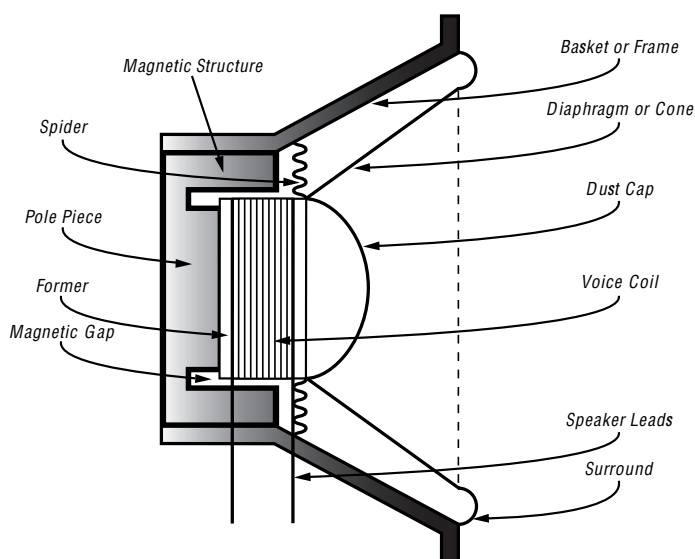

The coil of wire (called a “voice coil,” going back to the days of Alexander Graham Bell) is attached to some sort of diaphragm, and a suspension is created to allow the coil/diaphragm assembly to move back and forth like a piston. Thanks to the larger surface area of the diaphragm, enough air is moved to create adequate amounts of sound. (Left to itself, the voice coil alone would move nicely enough, but it would not create much sound, since it would not be effective at moving much air.)

Dynamic drivers illustrate beautifully the many tradeoffs listed above. They must be **large**, in order to move enough air to play at high levels;

yet they must be **light**, so inertia does not prevent them from vibrating quickly enough to reproduce high notes; yet they must be **rigid**, to translate accurately the motion of the coil into the corresponding motion of air; yet this large, rigid and light object must not tend to vibrate of its own accord, since those vibrations would color the sound the driver is trying to reproduce. There are simply too many conflicting goals for unqualified success.

In response to these difficulties, all high quality dynamic loudspeakers use multiple dynamic drivers, and divide the sounds we hear into ranges suitable for each specialized driver. Hence the large woofers and tiny tweeters you have seen, as well as midranges, subwoofers and other variations on the theme. Since these drivers are so varied and have such wildly differing characteristics, getting them all to blend seamlessly — especially throughout the critical midrange where our ears are most sensitive — is a major challenge. Even

within their intended operating ranges, they are still less than entirely successful. As you begin to appreciate the nature of the problem, it becomes remarkable that the best dynamic speakers have achieved their current level of performance.

Electrostatic drivers

Audiophiles around the world know the appeal of electrostatic speakers, though many non-enthusiasts are less familiar with them and may imagine that they are a recent development. In fact, “electrostats” have been around for almost as long as dynamic speakers. Peter Walker Founded the British company QUAD in 1936, and QUAD speaker designs going back as far as the 1950’s are still sought after for the purity of their sound.

Electrostatic speakers (ESLs) use no magnets at all, instead relying on the force that makes your socks cling together when you pull them from the clothes drier. A thin film material (think of it as a high-tech version of the plastic wrap in your kitchen drawer) is stretched on a frame, and a static electrical charge is placed on it. It is placed between two rigid metal screens that hold a high-voltage version of the signal coming from your power amplifier. When the front screen has a positive charge, the rear screen has an equal-but-negative charge. Since opposites attract and like charges repel, the static charge on the thin film is pushed from one side and pulled from the other. As the charges on the screens change, the thin film material moves back and forth, in an extremely accurate analog of the signal being fed into the speaker.

Electrostatic speakers are justifiably famous for being wonderfully detailed, revealing the most subtle nuances of the music. This fact is due to several causes:

- **Responsive.** The moving mass is *extremely* low (lower, in fact, than the mass of the air it is moving), which means little inertia to blur any details in the musical signal.
- **Low distortion.** The force acting on the thin film diaphragm is acting on the entire surface, so there is no tendency for the film to flex or “break up” as there is with dynamic cones and domes (which are driven only by the voice coil).
- **Controlled dispersion.** Tall and narrow ESLs can be designed to radiate sound as a “line source,” which results in fewer unwanted reflections of sound from ceilings and floors. This trait can often make the ill effects of the room’s acoustics less evident.

Given all these wonderful advantages, why are electrostatic speakers relatively rare?

Unfortunately, electrostatic speakers have some major limitations:

- **ESLs are big.** The electrostatic forces acting on the thin film diaphragm are relatively weak. As a result, the metal screens must be brought quite close together to make the most of what force there is, which limits the excursion of the thin film *between* the screens. Since the forward-and-back excursion is extremely

small, electrostatic speakers can only play loudly if they are quite large in area (height and width).

Speakers as big as (or bigger than) the adults listening to them are often difficult to incorporate into a room's decor.

- **ESLs lack deep bass.** Despite their size, ESLs generally have trouble reproducing deep bass. This is also because the thin film diaphragm simply does not have enough room to move very far, and reproducing deep bass requires the movement of a *lot* of air. It is also because they lack any enclosure that would prevent the sound coming from the back of the speaker from canceling out the sound emanating from the front. At low frequencies, this cancellation is a real problem. (For this reason, the most successful ESL designs are often “hybrid” designs that combine a dynamic woofer for the bass with an ESL panel for the mids and highs.)
- **ESLs need a lot of space.** Technically, ESLs are “dipoles” meaning that they radiate sound equally from their front and backs, in a push-pull fashion. In order to minimize the effect of the back wave bouncing off the wall in the front of the room and interfering with the front wave, ESLs need to be placed somewhat out into the room for best effect. This makes an already large speaker even more imposing, and takes up a fair amount of living space. It also makes ESLs impractical for any on-wall or in-wall application.
- **ESLs can be hard on amplifiers.** Unless something is done to address the natural impedance of an ESL driver, it tends to be highly “reactive” (it acts like a big capacitor) and to have a low overall “impedance” (meaning that, at some frequencies it looks like a short circuit from the amplifier's point of view). Both of these conditions make it difficult for your power amplifier to sound as good as it might otherwise — they place a great deal of stress on the amplifier. The most common solution is to employ a transformer as a buffer between the amplifier and the speaker (which also increases the voltage that the amplifier supplies to the ESL panel). The problem is that it is difficult and costly to make a transformer that can handle a lot of power equally well across the entire range of frequencies we care about in music. Not impossible, to be sure; but not easy, and definitely at a price.
- **ESLs need AC power.** Since the electrostatic panels need to be charged to a high voltage in order to operate, ESLs need to have power supplies that are plugged into an AC outlet. While they do not actually consume much power, the necessity of having an AC outlet near each speaker complicates the installation, and is yet another obstacle in the way of enjoying such speakers that might otherwise offer so much in terms of performance.

Ribbon drivers

You might think of a pure ribbon speaker as a first-pass attempt at combining dynamic and ESL principles.

Imagine a pleated strip of thin aluminum foil placed between two powerful magnets, one at each edge. (Technically, it could be any conductor, but aluminum is light and relatively flexible, and is the usual choice.) Sending an electrical current through this foil induces a magnetic field around it, just as in the case of a normal voice coil. The magnetic field created by the musical signal running through the pleated “ribbon” of metal interacts with the unchanging magnetic field of the two powerful magnets on either side, and induces the ribbon itself to move in response to the music.

This design approach has much to commend it. The strength of the magnetic field acting on the diaphragm can be quite intense (unlike the field strength of ESLs), and it covers the entire ribbon uniformly (as with ESLs). These facts ensure accurate motion, since there is a strong force acting over the entire area of a lightweight diaphragm.

However, ribbon speakers as described above have generally been limited to use as high frequency drivers (tweeters, or even “super-tweeters” that go beyond the range of human hearing), since it is difficult to build a true ribbon driver large enough to handle anything else. This is partly because the pleated shape is easily damaged by excessive excursion, or even by its own weight if it is made too large. The pleating is necessary for the free motion of the metal foil, forming as it does the suspension of the diaphragm. However, excessive excursion can stretch and effectively flatten the pleats, after which the ribbon sags in the magnet gap and performs poorly. These drivers thus tend to be small and limited to high frequencies, where excursions are minimal, and the ribbon can more easily support its own weight.

However, even limiting these delicate drivers to a high frequency role does not solve all their problems. They are also extremely sensitive to anything that might deform the delicate ribbon itself, whether an accidental drop, or an inquisitive child’s touch. Think of how easily household aluminum foil can be creased, and then imagine aluminum foil that is a small fraction of the thickness... clearly it would not take much to deform and damage it.

In addition, true ribbon speakers present a dangerously low impedance to the power amplifiers that drive them. The small ribbon of metal foil presents almost no resistance to the flow of electricity, which (left alone) would look quite like a short circuit to the amplifier. Even if the amplifier itself is not damaged, or avoids going into a protection mode, few amplifiers are going to sound their best when presented with a 0.1Ω load. It represents entirely too much stress to the output stage of the amplifier. Most ribbons use a transformer to mitigate this problem. Unfortunately (as with ESLs), the transformers themselves can limit the ultimate performance of the ribbon driver.

If only we could combine the best of ESL designs (*detail, low distortion, and even, controlled dispersion in certain applications*) with the best of dynamic speaker designs (*high reliability, large dynamic range, high sensitivity, relatively easy load for the amplifiers*)....

Planar magnetic drivers

We finally arrive at planar magnetic drivers (PMDs). When implemented properly, you can think of them either as particularly robust ribbons, or as easy-to-drive electrostatics with a lot more dynamic range. Or perhaps both.

The core distinction between a ribbon and a planar magnetic is the diaphragm material: in a true ribbon speaker, the conductor *is* the diaphragm, whereas in a planar magnetic speaker, the conductor is intimately attached to a lightweight but far more rugged diaphragm material that is similar to that used in ESL speakers.

Think back to the description of an electrostatic loudspeaker: a thin film diaphragm was stretched on a rigid frame, and sandwiched between electrically-charged panels. In the case of a planar magnetic speaker, the thin film is sandwiched between arrays of bar magnets instead, and the “voice coil” is unwound and spread across the thin film, much as your rear window defogger in your car runs back and forth through the glass. By connecting the amplifier to this conductor attached to the thin film, current flows, and a changing magnetic field is created that interacts with the bar magnets, causing the diaphragm to move.

- **Highly detailed.** Planar magnetic drivers are like ESLs in that the moving mass of the diaphragm is extremely small, lighter even than the air it moves. It can therefore be driven with both delicacy and accuracy, without the blurring effects of excessive inertia.
- **More reliable.** Planar magnetics have a huge advantage over traditional dynamic drivers, in that the “voice coil” is spread out over a large area rather than squeezed into a narrow gap within a massive chunk of metal. As a result, planar magnetic drivers can dissipate heat effectively that would otherwise build up in the voice coil. Planar magnetic speakers can handle *a lot* of power without undue stress or audible strain. In fact, for a given surface area, they can handle *many times* the power of a traditional dynamic driver.
- **Easy on amplifiers.** Well-designed planar magnetic speakers present an almost perfectly resistive load to the power amplifier in the system, since the voice coil is essentially a very long, thin wire. It acts like a simple resistor. This is the easiest possible load for the amplifier to drive, and comparable to the one electronics manufacturers use during measurements designed to show how terrific their products are. As a result, you can count on your amplifier sounding its best.
- **Either dipole or monopole.** The nature of planar magnetic designs make it relatively easy to design them to either be dipole (radiating equally and in opposite phase in front of and behind the speaker, like ESLs) or monopole (radiating only in the forward direction, more like a traditional dynamic speaker). This presents

some interesting possibilities for on-wall or even in-wall designs that could combine exceptionally high performance with relatively little impact on the domestic front.

Sounds quite attractive, doesn't it? Unfortunately, planar magnetics have their shortcomings, as well.

Not a panacea...

There are some significant challenges to building a planar magnetic device that lives up to the impressive potential outlined above.

Deep bass

While a well-designed planar magnetic system can move much more air than a comparably-sized ESL (thanks to the stronger forces and larger excursions available), a truly full-range PMD would still have to be quite large. As with ESLs, the most successful PMDs will generally be hybrid devices that complement the excellent soundstaging and detail of the planar device with a more traditional, dynamic woofer.

Heat

The thin film material must be able to withstand significant heat. While electrostatic loudspeaker films never get hot (since no electrical current runs through them), planar magnetic thin films are intimately attached to the voice coil, which may see many amperes of current during musical peaks or climactic moments in movies.

Even today, many planar magnetic speakers use PET film (a common trade name is Mylar™). While PET has some desirable traits, it becomes quite soft at temperatures above 175-195°F (80-90° C). When this happens, it can deform, wrinkle and introduce a lot of distortion. After this has happened, the speaker is usually never quite the same again. A thin film with better tolerance of high temperatures is needed.

In addition to the thin film material itself, there is usually an adhesive that bonds the voice coil to the film, and it too must withstand the heat.

In some ways, planar magnetics have an advantage here, in that there are only about three glue joints in a typical PMD, as opposed to about ten in a typical dynamic driver. Also, heat can easily radiate away from the flat voice coil in a PMD, whereas it tends to get trapped within the motor structure of a traditional dynamic driver.

Still, the adhesive must withstand the same heat that the thin film material must, since it is responsible for bonding the voice coil to the diaphragm. Given the demands of modern, highly dynamic program material, this is a significant challenge — even with the advantages of a PMD design.

Consistency

The tension of the thin film across its frame is a critical component of the overall design. It effectively replaces the entire suspension system of a dynamic driver (spiders, surrounds, etc.), favoring a trampoline motion over a pistonic one. Getting the tension just right, and the same in all directions, is critical to success and not easily achieved in the manufacturing process. (This is equally challenging for manufacturers of ESLs, by the way.)

Wisdom Audio planar magnetic technology

Wisdom Audio has developed a number of planar magnetic technologies that fully capitalize on the strengths of PMDs while mitigating or even eliminating the few weaknesses. While it is impossible to claim that any speaker is perfect, some do get significantly closer than others... and Wisdom Audio leads the way.

Neodymium magnets

Wisdom Audio planar magnetic drivers use costly “rare earth” or neodymium magnets, which provide a vastly stronger magnetic field than conventional magnets, while using fewer and smaller ones. This vital difference yields a number of critical improvements over what was possible only a few years ago:

- **High sensitivity.** The higher field strength of these remarkable magnets (as compared to normal ceramic or ferrite magnets, and certainly as compared to ESL panels) means that your amplifier does not have to work nearly as hard to deliver a satisfactory listening experience.
- **Plays louder and lower.** Since the magnetic field is so much stronger, it becomes possible to open up the space between the front and rear magnet arrays, giving the diaphragm more room to move. Since it can move further, it can move more air for its size and therefore play both more loudly and lower in frequency than a comparably-sized ESL panel, or older-style planar magnetics. (In fact, an ESL panel must be between *ten and twenty times larger* than the equivalent Wisdom Audio planar magnetic in order to achieve comparable performance.)
- **Tighter control.** Since the force acting on the lightweight diaphragm is so high and spread uniformly over its surface, the motion of the diaphragm is strictly controlled. Advanced methods of diaphragm resonance suppression damp out motion of the undriven portions of the diaphragm (near the edges). Spurious motion due to inertia or resonances is vanishingly small as compared to traditional dynamic designs, and on a par with the best ESLs.
- **Reduced coloration.** The arrays of older, bulkier bar magnets got in the way of the sound that the diaphragm was creating, coloring the sound that was otherwise so detailed and remarkable. Since the neodymium magnets are a fraction of the size, there is dramatically more open space on either side of the

diaphragm and the colorations disappear. In particular, the magnets in front of the diaphragm are extremely slim and offer virtually no interference with sound.

- **Controlled directivity.** When you can make a diaphragm in virtually any shape and still have its entire active surface operating as one (in phase), it becomes possible to design drivers with extremely specific dispersion patterns that have direct performance benefits. For example: musical detail and dialog intelligibility are both enhanced if you can minimize spurious reflections in your listening room. With a tall and narrow design, you can provide wide dispersion to support a generous seating area, while minimizing the energy bouncing off ceilings and floors. In short, you hear more of the speaker, and less of your room.

Advanced thin film

Wisdom Audio is one of the first companies to abandon PET (Mylar™) in favor of more advanced materials that have superior dynamic and temperature characteristics. Of these, the polyimide family of polymers is the most promising, some of which can handle temperatures in excess of 725°F (385°C) — far in excess of what even the most advanced adhesives could hope to withstand. Fortunately, this is also a temperature range unlikely to be experienced by any planar magnetic driver, except perhaps in the most demanding professional applications.

The best adhesive is no adhesive

There is a particular case when extremely high temperatures are likely, however: in a small, two-way design in which a 3" planar magnetic driver is being used down to the extreme lower limit of its range (about 500 Hz), fully five of the ten octaves we can hear will be reproduced by that one small driver. This forces a great deal of power into a small space, resulting in less radiating area for heat dissipation. Temperatures on the voice coil and the diaphragm in such situations can easily spike to 450°F (230°C) on a temporary basis, even though they might be quickly dissipated.

There is no adhesive that is suitable for this application that can withstand those temperatures. None.

Wisdom Audio has pioneered a manufacturing process for this specific application wherein the diaphragm material is deposited directly to the aluminum. This process forms a direct molecular bond between the diaphragm and the voice coil, without the use of any layer of glue in between. This approach completely eliminates the weak link in the chain, and makes it possible to have a 3" midrange/tweeter PMD that can handle enormous amounts of power. This fact in turn supports designing a smaller loudspeaker than could otherwise be achieved.

Moreover, the elimination of the adhesive layer reduces the moving mass of the diaphragm assembly — which is especially important at higher frequencies. The adhesive that ordinarily bonds the thin film to the foil conductor covers the entire diaphragm, and (depending on the type used) can weigh as much as half the diaphragm itself. Eliminating the mass of the adhesive layer can improve sensitivity by as much as 1½ to 2 dB, which can sometimes be critical in such a small driver.

Note that larger planar magnetic drivers are never subjected to such a high power/area ratio, and their larger surface area also creates higher sound pressure levels with ease. Thus the added cost of the adhesiveless approach is neither necessary nor warranted in larger drivers.

Pleated diaphragms

Wisdom Audio thin film diaphragms are pleated using a proprietary, high pressure process that enhances the thermodynamic stability of the diaphragm while increasing its overall excursion capability. Sensitivity is improved, while standing waves on the surface of the diaphragm are all but eliminated. As a result, these planar magnetic drivers manage to best even other strong planar magnetic designs in terms of both detail and dynamics.

The difference is not subtle. Compare these speakers to any other high performance design: dynamic, ESL, ribbon, or planar magnetic, and you will hear the music come alive in a way that speaks directly to your emotions. They are incredibly engaging. They must be heard to be appreciated.

Summary

Planar magnetic driver technology offers significant benefits over traditional dynamic driver technologies, especially at all frequencies above the bass (where dynamic drivers still tend to make the most sense). PMDs provide superior detail, outstanding dynamic range, and controlled directivity as compared to alternative technologies, all of which add up to create a more consistent and realistic level of performance in your home.

Wisdom Audio is a leader in the development of PMD technology, pushing it to new heights of performance while addressing some of the inherent limitations of planar magnetic designs. The many patented innovations seen in Wisdom Audio products are a testimony to both the experience and the creativity of those involved, some of whom have been designing planar magnetic drivers for over thirty years. If you have not yet auditioned a Wisdom Audio system, we strongly encourage you to do so.