

L75 Loudspeaker

Available in On-Wall, In-Wall and Freestanding versions.

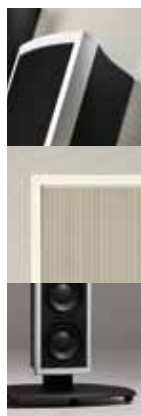

L75 Loudspeaker

The L75 benefits from the same core technologies and design elements of the Sage Series flagship L150i packaged in a more compact and flexible form. It combines our state-of-the-art transducer elements in a way that takes full advantage of their inherent performance benefits.

The L75 can be used in in-wall (L75i), on-wall (L75m) or free-standing (L75) applications. These versions can also be mixed and matched for the specific needs of the installation. All versions are constructed entirely from aircraft grade aluminum. Slim and elegant in design, the freestanding and on-wall versions of the L75 blend nicely into a variety of décors where traditional loudspeakers might otherwise intrude excessively on the room's appearance. Their clear anodized interlocking trim bezels and matte charcoal colored cabinet convey an exquisite balance of industrial design and build quality unique among consumer loudspeakers. The narrow aspect L75i in-wall design becomes one with the wall, via its paintable grill and bezel, while its all aluminum chassis and integral back box enclosure ensure optimal and consistent performance regardless of mounting environment.

The L75 employs a 48-inch planar magnetic line source to reproduce everything above 275 Hz and four unusually robust, high operating pressure 6-inch woofers for the bass. Incorporating true line sources is unprecedented among architectural speakers. Since true line source arrays effectively eliminate floor and ceiling reflections, they are ideal for large rooms or those with architectural challenges including cathedral or coffered ceilings, hard floors, etc. The L75's 48-inch tall line source driver complement allows for high resolution, low distortion and superior dynamic range. The result is highly detailed, dynamically accurate, genuinely effortless performance at any volume level.

The true line source behavior of the L75 exhibits less propagation loss than any conventional loudspeaker, resulting in a vastly enlarged "sweet spot" that is particularly beneficial in any situation with a large seating area. Whether in a media room with a casual seating arrangement or dedicated home theaters with multiple rows of seating, everyone in the audience is treated to "money seat" performance.

As with all Sage Series systems, the 7.3 channel SC-1 System Controller is the heart of the system. It provides the active crossover between bass and midrange/treble, system-specific EQ, as well as Audyssey MultEQ® XT room correction on all 17 output channels for consistent no-compromise performance in every installation.



The Excite Award
September 6, 2008



The Resi Award
September 4, 2008

For those customers seeking a flexible application, high performance architectural loudspeaker, the L75 is the solution. Merging the benefits of the superior qualities of a true PMD line source and outstanding low frequency performance, the L75 defies categorization. Capable of unprecedented dynamics, low distortion, high resolution, faithful timbre reproduction, three dimensional sound

staging and freedom from compression, this system can be compared with the best freestanding systems and needs to be auditioned to be fully appreciated.



Wisdom Audio
 1572 College Parkway, Suite 164
 Carson City, NV 89706
 775-887-8850
 fax 775-887-8820
 www.wisdomaudio.com
 information@wisdomaudio.com

The World's Most Advanced Architectural Loudspeakers.™

L75 Specifications

All specifications are subject to change at any time, in order to improve the product.

Frequency response	40Hz – 20kHz ± 2dB relative to the target curve
Frequency response, 30° off horizontal axis	40Hz – 18kHz ± 2dB relative to the target curve
Impedance, planar section	4.5 ohms
Impedance, woofer section	3 ohms
Sensitivity, planar section	95 dB / 2.83 V / 1m
Sensitivity, woofer section	91 dB / 2.83 V / 1m
Shipping weight:	
each L75	79 lbs. (36 kg)
pair of L75 bases	30 lbs. (14 kg)
each L75m	69 lbs. (31 kg)
each L75i	65 lbs. (29 kg)

L75m, On-wall

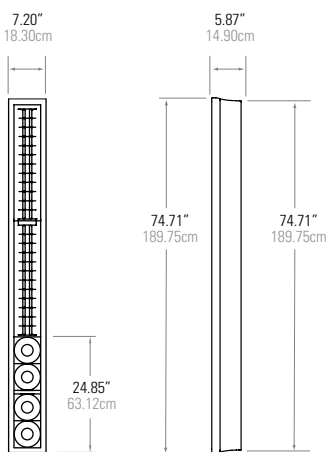

L75i, In-wall

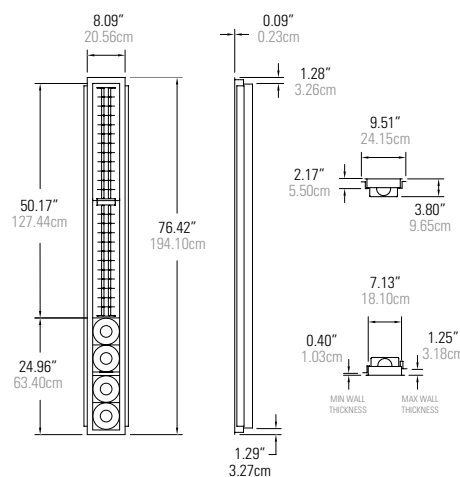

L75, Freestanding

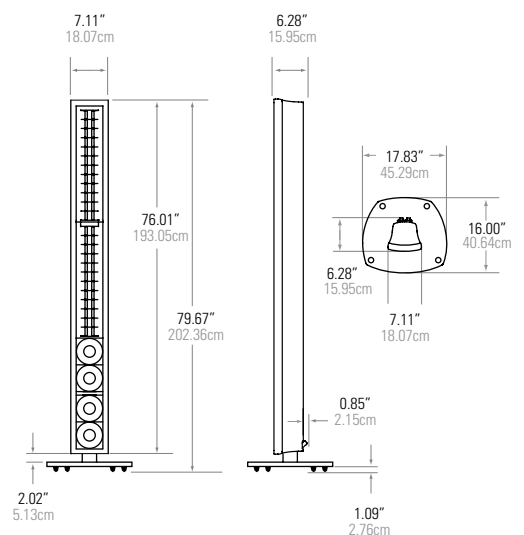

L150 Loudspeaker

Available in In-Wall and On-Wall versions.



L150 Loudspeaker

The L150 is our premier expression of the core technology and strengths of the Sage Series, designed for those customers that demand the highest level of sonic refinement and performance available in an architectural speaker. It combines our state-of-the-art transducer elements in a way that takes full advantage of their inherent performance benefits. It offers a no-compromise solution for customers that require a high-end audiophile loudspeaker that fully integrates into their home. The Sage Series L150 is an unparalleled effort and serves as a benchmark for industry leading architectural products available today.

The L150 can be used for in-wall (L150i), or on-wall (L150m) applications. These versions can also be mixed and matched for the specific needs of the installation. All enclosures are constructed entirely from aircraft grade aluminum. Slim and elegant in design, the L150m on-wall integrates easily with a variety of décors where traditional loudspeakers might otherwise intrude excessively on the room's appearance. Their clear anodized interlocking trim bezels and matte charcoal colored cabinet convey an exquisite balance of industrial design and build quality unique among consumer loudspeakers. The narrow aspect ratio L150i in-wall design becomes one with the wall, via its paintable grill and bezel, while its all aluminum chassis and integral back box enclosure ensure optimal and consistent performance regardless of mounting environment.

The L150 is the tallest line source in our Sage Series. Incorporating true line sources of this length is unprecedented among in-wall and on-wall speakers. Since true line source arrays effectively eliminate floor and ceiling reflections, they are ideal for large rooms or those with architectural challenges including cathedral or coffered ceilings, hard floors, etc. The large, 76-inch tall line source driver complement allows for high resolution, low distortion and extraordinary dynamic range. The result is highly detailed, dynamically accurate, genuinely effortless performance at any volume level.

The true line source behavior of the L150 exhibits less propagation loss than any conventional loudspeaker, resulting in a vastly enlarged "sweet spot" that is particularly beneficial in any situation with a large seating area. Whether in a media room with a casual seating arrangement or dedicated home theaters with multiple rows of seating, everyone in the audience is treated to "money seat" performance.

The L150 consists of two 76-inch tall by 8-inch wide cabinets per channel, with the woofer cabinet crossing over to the mid/high frequency planar magnetic line source cabinet at 275Hz. The mid/high frequency cabinet builds upon the planar magnetic line source array of the Sage Series' L75 model, incorporating three 24-inch PMD drivers resulting in a 72-inch true line source, yielding superior resolution, extraordinary dynamic capability, low distortion and wide dispersion.

The low frequency cabinet within the L150 incorporates twelve proprietary high operating pressure woofers. Each woofer cabinet is driven by a single SA-1 amplifier, thereby using a combined 1,000 watts from its two 500-watt amplifier channels for the 12 woofers. Each channel is a two-cabinet system designed to be installed in-wall or on-wall, adjacent to each other, within four or five inches of each other (flanking a stud in in-wall installations).

Considering the center channel handles the majority of soundtracks' vocals and dynamics, we also offer a no-compromise option to those customers who want the best performance possible from their center channel, the C150 Center Channel. The C150i (in-wall) and C150m (on-wall) models incorporate



China's Home Theater Tech Magazine
December, 2009



The Excite Award
September 10, 2008



CE Pro BEST Award
Finalist
September 10, 2009



Residential Systems
Finalist
September 10, 2009



Manufacturers' Excellence Award
Finalist
July 21, 2009

a 50-inch tall planar magnetic line source for mid and high frequencies, accompanied by two woofer arrays, each containing eight proprietary high operating pressure woofers for a total of sixteen woofers. Because the C150 is a line source, it requires installation behind an acoustically transparent screen and is not able to be mounted horizontally either below or above the screen. In such installations (as in professional cinemas), having the center channel information delivered from behind the screen lends a sense of coherence and vocal localization that provides an even more engaging experience for the listener. Of course, for those who wish to do so, it is entirely possible to use the C150 for the left and right channels behind the screen, as well.

As with all Sage Series systems, the 7.3 channel SC-1 System Controller is the heart of the system. It provides the active crossover between bass and midrange/treble, system-specific EQ, as well as Audyssey™ MultEQ® XT room correction on all 17 output channels for consistent no-compromise performance in every installation.

For those customers seeking the ultimate architectural loudspeaker, the L150 is the solution. Merging the benefits of an integrated loudspeaker with the superior qualities of a true PMD line source and outstanding low frequency performance, the L150 is in a class by itself. Capable of unprecedented dynamics, low distortion, high resolution, faithful timbre reproduction, three dimensional sound staging and freedom from compression, this system should be compared with the best freestanding systems and needs to be auditioned to be fully appreciated.



Wisdom Audio
1572 College Parkway, Suite 164
Carson City, NV 89706
775-887-8850
fax 775-887-8820
www.wisdomaudio.com
information@wisdomaudio.com

The World's Most Advanced Architectural Loudspeakers.™

L150 Specifications

All specifications are subject to change at any time, in order to improve the product.

Frequency response	30Hz – 20kHz ± 2dB relative to the target curve
Frequency response, 30° off horizontal axis	30Hz – 18kHz ± 2dB relative to the target curve
Impedance, planar section	3 ohms
Impedance, woofer section	6 ohms
Sensitivity, planar section	96 dB / 2.83 V / 1m
Sensitivity, woofer section	96 dB / 2.83 V / 1m
Shipping weight:	
Bass section	90 lbs. (41 kg)
Planar section	53 lbs. (24 kg)

L150i, In-wall

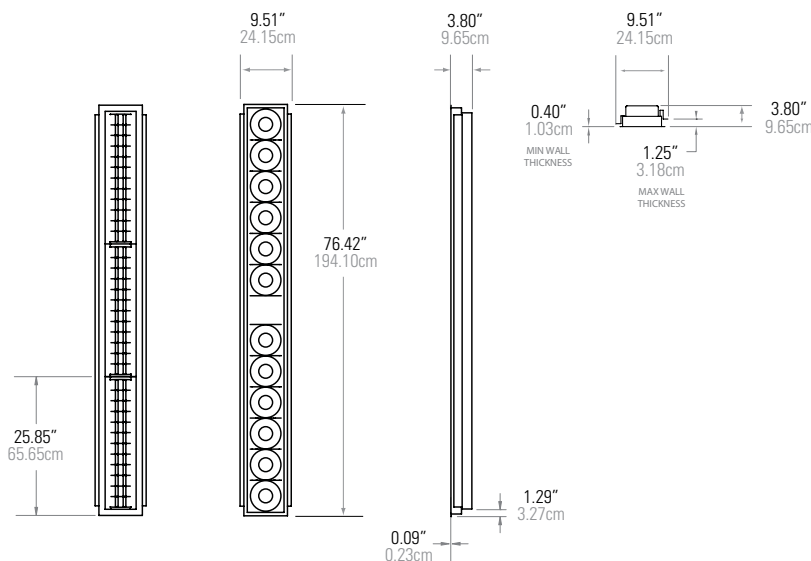

L150m, On-wall

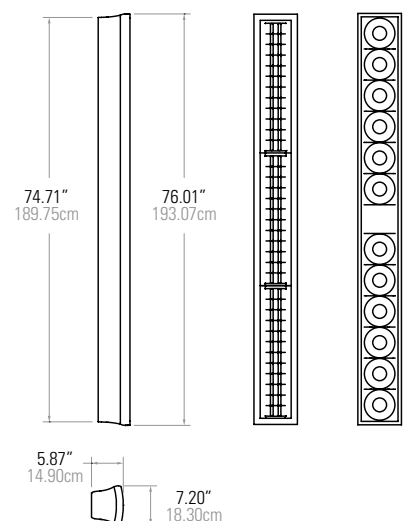

L100 Loudspeaker

Available in In-Wall and On-Wall versions.



L100 Loudspeaker

Today, several high-end projection screen companies have developed innovative material technologies that allow the use of speakers behind the viewing surface so as to not compromise video or audio performance. These new screen materials provide rich visual detail while also keeping the front speakers hidden from the audiences' view. Marrying the concept of superior audio and video solutions, the screen materials' design allows for unsurpassed audio quality from the hidden speakers while maintaining high-end video performance.

The L100i (in-wall) and L100m (on-wall) Sage Series models feature the same line source planar magnetic technology found in the Sage Series L75 and L150, but measuring a more compact 50 inches in height. They are able to be completely hidden behind a wide array of acoustically transparent screens, including the popular 2.35:1 aspect ratio screens of suitable width. The L100 incorporates a 50-inch tall planar magnetic line source for mid and high frequencies, accompanied by a woofer array containing eight proprietary high operating pressure woofers. Each woofer cabinet is driven by a single SA-1 amplifier, thereby using a combined 1,000 watts from its two 500-watt amplifier channels for the 8 woofers. Each channel is a two-cabinet system designed to be installed in-wall or on-wall, adjacent to each other, within four or five inches of each other (flanking a stud in in-wall installations).

Considering the fact that the center channel handles the majority of soundtracks' vocals and dynamics, we also offer a no-compromise option to those customers who want the best performance possible from their center channel, the C150 Center Channel. The C150i (in-wall) and C150m (on-wall) models incorporate a 50-inch tall planar magnetic line source for mid and high frequencies, accompanied by two woofer arrays, each containing eight proprietary high operating pressure woofers for a total of sixteen woofers. Because the C150 is a line source, it requires installation behind an acoustically transparent screen and is not able to be mounted horizontally either below or above the screen. In such installations (as in professional cinemas), having the center channel information delivered from behind the screen lends a sense of coherence and vocal localization that provides an even more engaging experience for the listener. Of course, for those who wish to do so, it is entirely possible to use the C150 for the left and right channels behind the screen, as well.

As with all Sage Series systems, the 7.3 channel SC-1 System Controller is the heart of the system. It provides the active crossover between bass and midrange/treble, system-specific EQ, as well as Audyssey™ MultEQ® XT room correction on all 17 output channels for consistent no-compromise performance in every installation.

For those customers seeking a high performance architectural loudspeaker that can be installed in locations where the flagship L150 is not practical, the L100 is the solution. Merging the benefits of an integrated loudspeaker with the superior qualities of a true PMD line source and outstanding low frequency performance, the L100 stands far above conventional architectural speaker systems. Capable of unprecedented dynamics, low distortion, high resolution, faithful timbre reproduction, three dimensional sound staging and freedom from compression, this system should be compared with the best freestanding systems and needs to be auditioned to be fully appreciated.



Wisdom Audio
 1572 College Parkway, Suite 164
 Carson City, NV 89706
 775-887-8850
 fax 775-887-8820
 www.wisdomaudio.com
 information@wisdomaudio.com

The World's Most Advanced Architectural Loudspeakers.™

L100 Specifications

All specifications are subject to change at any time, in order to improve the product.

Frequency response	40Hz – 20kHz ± 2dB relative to the target curve
Impedance, <i>planar section</i>	4.5 ohms resistive
Impedance, <i>woofer section</i>	4 ohms nominal, 2.5 ohms minimum
Sensitivity, <i>planar section</i>	95 dB / 1w / 1m
Power handling, <i>peak</i>	>1000w
Shipping weight:	
<i>Bass section</i>	62 lbs. (28 kg)
<i>Planar section</i>	32 lbs. (14.5kg)

L100i, In-wall

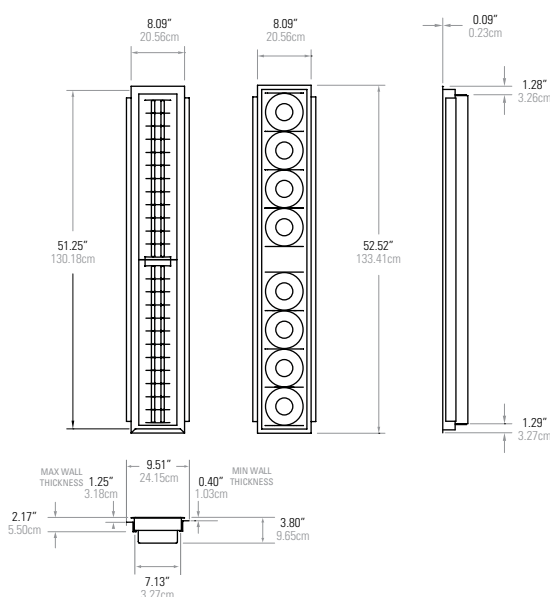

L100m, On-wall

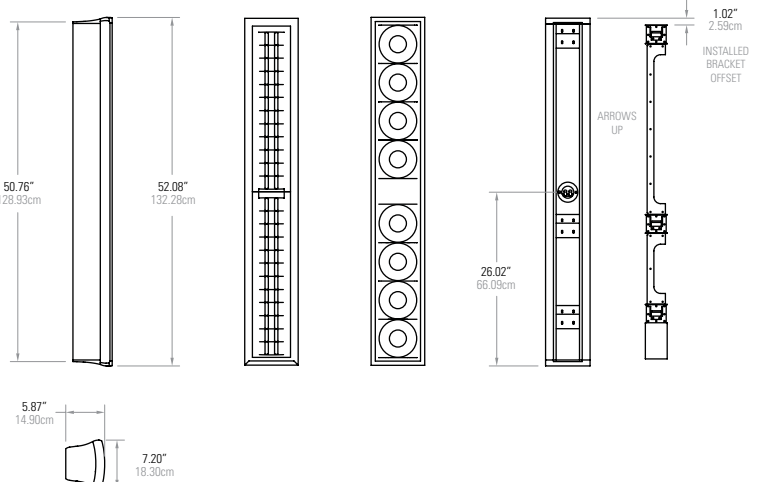

C150 Loudspeaker

Available in In-Wall and On-Wall versions.



C150 Loudspeaker

Today, several high-end projection screen companies have developed innovative material technologies that allow the use of speakers behind the viewing surface so as to not compromise video or audio performance. These new screen materials provide rich visual detail while also keeping the front speakers hidden from the audiences' view. Marrying the concept of superior audio and video solutions, the screen materials' design allows for unsurpassed audio quality from the hidden speakers while maintaining high-end video performance.

Considering the center channel handles the majority of soundtracks' vocals and dynamics, we also offer a no-compromise option to those customers who want the best performance possible from their center channel, the C150 Center Channel. The C150 features the same line source planar magnetic technology found in the Sage Series L150, but measures a more compact 50 inches in height. It is able to be completely hidden behind a wide array of acoustically transparent screens, including the popular 2.35:1 aspect ratio screens of suitable width. The C150i (in-wall) and C150m (on-wall) models incorporate a 50-inch tall planar magnetic line source for mid and high frequencies, accompanied by two woofer arrays, each containing eight proprietary high operating pressure woofers for a total of sixteen woofers. Each woofer cabinet is driven by a single SA-1 amplifier, thereby using a combined 1,000 watts from its two 500-watt amplifier channels for the 8 woofers (2,000 watts combined for the 16 woofers). The C150 is a three-cabinet system designed to be installed in-wall or on-wall, with the planar cabinet centered between the woofer arrays, within four or five inches of each other (flanking studs in in-wall installations).

Because the C150 is a line source, it requires installation behind an acoustically transparent screen and is not able to be mounted horizontally either below or above the screen. In such installations (as in professional cinemas), having the center channel information delivered from behind the screen lends a sense of coherence and vocal localization that provides an even more engaging experience for the listener. Of course, for those who wish to do so, it is entirely possible to use the C150 for the left and right channels behind the screen, as well.

As with all Sage Series systems, the 7.3 channel SC-1 System Controller is the heart of the system. It provides the active crossover between bass and midrange/treble, system-specific EQ, as well as Audyssey™ MultEQ® XT room correction on all 17 output channels for consistent no-compromise performance in every installation.

For those customers seeking the ultimate center channel loudspeaker that can be installed in locations where the

flagship L150 is not practical, the C150 is the solution. Merging the benefits of an integrated loudspeaker with the superior qualities of a true PMD line source and outstanding low frequency performance, the C150 stands far above conventional center channels. Capable of unprecedented dynamics, low distortion, high resolution, faithful timbre reproduction, and freedom from compression, this center channel speaker is without peer and needs to be auditioned to be fully appreciated.



Wisdom Audio
 1572 College Parkway, Suite 164
 Carson City, NV 89706
 775-887-8850
 fax 775-887-8820
 www.wisdomaudio.com
 information@wisdomaudio.com

The World's Most Advanced Architectural Loudspeakers.™

C150 Specifications

All specifications are subject to change at any time, in order to improve the product.

Frequency response	40Hz – 20kHz ± 2dB relative to the target curve
Impedance, <i>planar section</i>	4.5 ohms resistive
Impedance, <i>woofer section</i>	4 ohms nominal, 2.5 ohms minimum
Sensitivity, <i>planar section</i>	95 dB / 1w / 1m
Power handling, peak	>1000w
Shipping weight:	
<i>Bass section</i>	62 lbs. (28 kg)
<i>Planar section</i>	32 lbs. (14.5 kg)

C150i, In-wall

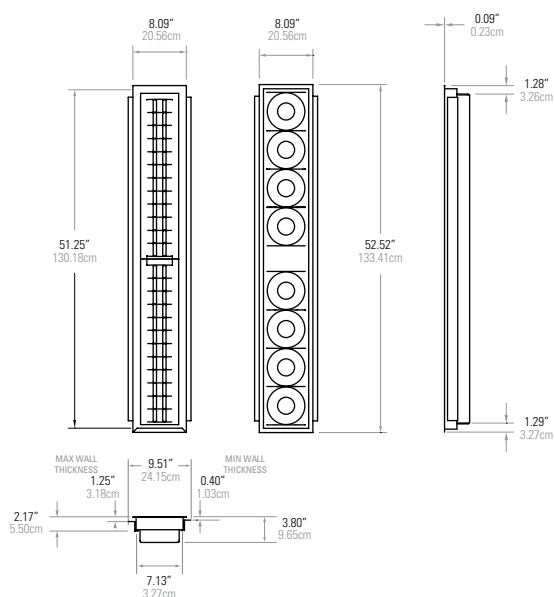

C150m, On-wall

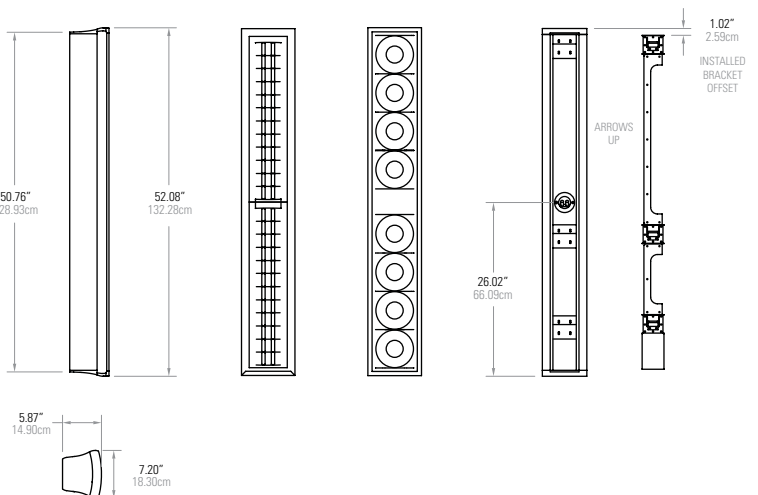

P48 Loudspeaker

Available in a Freestanding version.



P48 Loudspeaker

The P48 shares much in common with the P38, except that its design was specifically targeted for freestanding applications. It is not available in in-wall or on-wall versions. The P48 is not a line source like the L75 and L150i, but is instead a point source loudspeaker. The vast majority of loudspeakers available in the world are point sources, meaning that they radiate their sonic energy outward in an expanding sphere, as though from a point in space.

The P48 is available in a freestanding version only, and sharing the same driver technology, it is timbre matched and can be combined with other Sage Series in-wall, on-wall and freestanding models as is desired for the specific installation. Slim and elegant in design, the P48 blends nicely into a variety of décors where traditional loudspeakers might otherwise intrude excessively on the room's appearance. Constructed entirely from machined and extruded aircraft grade aluminum, the clear anodized interlocking trim bezels and matte charcoal colored cabinet convey an exquisite balance of industrial design and build quality unique among consumer loudspeakers.

Four of the same high operating pressure 6-inch woofers used in the L75 and L150i mate with a unique MTM Planar Magnetic Driver array for the midrange and treble. The MTM array provides the same level of transparency, detail, and instantaneous dynamics as the 24-inch Planar Magnetic driver used in the L75 and L150i (in multiples), but is a much smaller package optimized for the space requirements associated with the P48 and other more compact Sage Series models. The MTM array incorporates a groundbreaking 2-inch planar magnetic tweeter and two 2-inch midrange drivers. This combination of unique transducers is responsible for this series' characteristic transparency, detail and instantaneous dynamics, extending all the way down to 650 Hz.

As with all Sage Series systems, the 7.3 channel SC-1 System Controller is the heart of the system. It provides the active crossover between bass and midrange/treble, system-specific EQ, as well as Audyssey MultEQ® XT room correction on all 17 output channels for consistent no-compromise performance in every installation.

The P48 sonically presents itself in a room with the convincing authority normally associated with much larger loudspeakers. Employing planar magnetic drivers for the majority of its output, it is incredibly detailed and dynamic, and does not suffer from the sonic compression that plagues many conventional loudspeaker designs. The P48 provides stunning, lifelike dynamic music reproduction that belies its small footprint. Capable of the volume and dynamics normally associated with a live performance, the P48 can



fill a large space with ease. This compact system is an ideal solution for those listeners demanding a high resolution, low compression loudspeaker with a refined, contemporary, slim appearance that integrates easily with a range of décors.



Wisdom Audio
 1572 College Parkway, Suite 164
 Carson City, NV 89706
 775-887-8850
 fax 775-887-8820
 www.wisdomaudio.com
 information@wisdomaudio.com

The World's Most Advanced Architectural Loudspeakers.™

P48 Specifications

All specifications are subject to change at any time, in order to improve the product.

Frequency response	40Hz – 20kHz ± 2dB relative to the target curve
Frequency response, 30° off horizontal axis	40Hz – 18kHz ± 2dB relative to the target curve
Impedance, planar section	3 ohms
Impedance, woofer section	3 ohms
Sensitivity, planar section	90 dB / 2.83 V / 1m
Sensitivity, woofer section	91 dB / 2.83 V / 1m
Shipping weight:	
each P48	58 lbs. (26 kg)
pair of P48 bases	22 lbs. (10 kg)

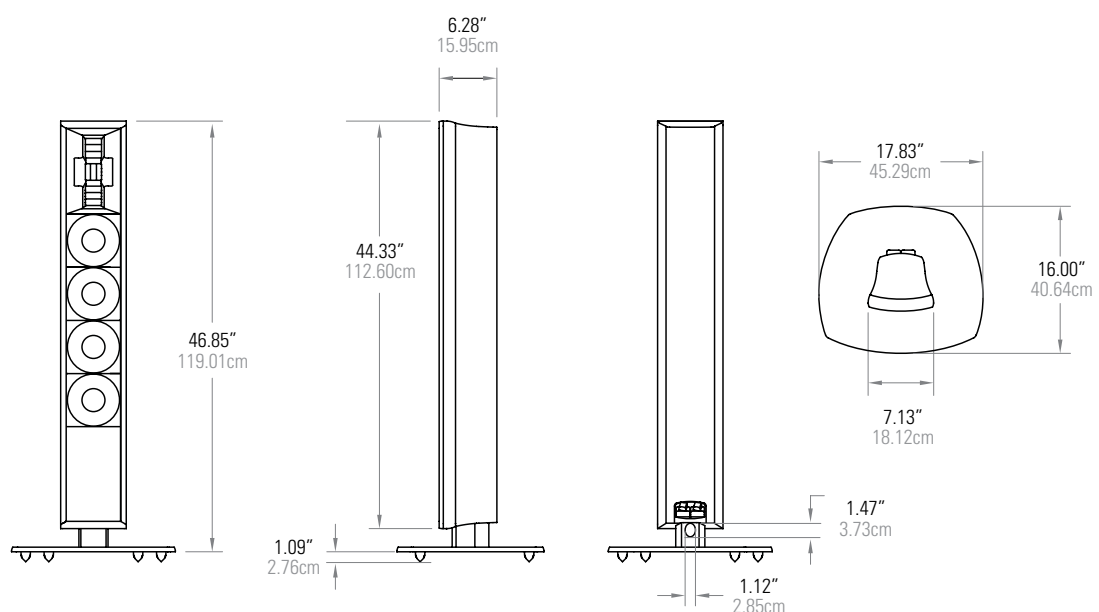

P38 Loudspeaker

Available in In-Wall and On-Wall versions.



P38 Loudspeaker

The P38 shares much in common with the P48, except that its design was specifically targeted for in-wall and on-wall applications. It is not available in a freestanding version. The P38 is not a line source like the L75 and L150i, but is instead a point source loudspeaker. The vast majority of loudspeakers available in the world are point sources, meaning that they radiate their sonic energy outward in an expanding sphere, as though from a point in space.

Sharing the same driver technology, it is timbre matched and can be combined with other Sage Series in-wall, on-wall and freestanding models as desired for the specific installation. Slim and elegant in design, the P38 can virtually disappear on a wall, intended to either match the “mounted,” on-wall design of a flat panel video display, or to be installed flush in the wall itself. Both versions are constructed entirely from machined and extruded aircraft grade aluminum. The clear anodized interlocking trim bezels and matte charcoal colored cabinet of the on-wall version convey an exquisite balance of industrial design and build quality unique among consumer loudspeakers. The narrow aspect P38i in-wall design becomes one with the wall, via its paintable grill and bezel, while its all aluminum chassis and integral back box enclosure ensure optimal and consistent performance regardless of mounting environment.

Four of the same high operating pressure 6-inch woofers used throughout Sage Series models mate with a unique MTM Planar Magnetic Driver array for the midrange and treble. The MTM array provides the same level of transparency, detail, and instantaneous dynamics as the 24-inch Planar Magnetic driver used in the L75 and L150i (in multiples), but is a much smaller package optimized for the space requirements associated with the P38 and other more compact Sage Series models. The MTM array incorporates a groundbreaking 2-inch planar magnetic tweeter and two 2-inch midrange drivers. This combination of unique transducers is responsible for this series’ characteristic transparency, detail and instantaneous dynamics, extending all the way down to 650 Hz.

As with all Sage Series systems, the 7.3 channel SC-1 System Controller is the heart of the system. It provides the active crossover between bass and midrange/treble, system-specific EQ, as well as Audyssey MultEQ® XT room correction on all 17 output channels for consistent no-compromise performance in every installation.

The P38 sonically presents itself in a room with the convincing authority normally associated with much larger loudspeakers. Employing planar magnetic drivers for the majority of its output, it is incredibly detailed and dynamic,

and does not suffer from the sonic compression that plagues many conventional loudspeaker designs. The P38 provides stunning, lifelike dynamic music reproduction that belies its slim profile and compact design. Capable of the volume and dynamics normally associated with a live performance, the P38 can fill a large space with ease. The P38m and P38i architectural loudspeakers deliver high definition sound that is a perfect complement to high definition video, while opening up new worlds of sonic performance for your musical enjoyment.



Wisdom Audio
 1572 College Parkway, Suite 164
 Carson City, NV 89706
 775-887-8850
 fax 775-887-8820
 www.wisdomaudio.com
 information@wisdomaudio.com

The World's Most Advanced Architectural Loudspeakers.™

P38 Specifications

All specifications are subject to change at any time, in order to improve the product.

Frequency response	40Hz – 20kHz ± 2dB relative to the target curve
Frequency response, 30° off horizontal axis	40Hz – 18kHz ± 2dB relative to the target curve
Impedance, planar section	3 ohms
Impedance, woofer section	3 ohms
Sensitivity, planar section	90 dB / 2.83 V / 1m
Sensitivity, woofer section	91 dB / 2.83 V / 1m
Shipping weight:	
each P38m	39 lbs. (18 kg)
each P38i	37 lbs. (27 kg)

P38i, In-wall

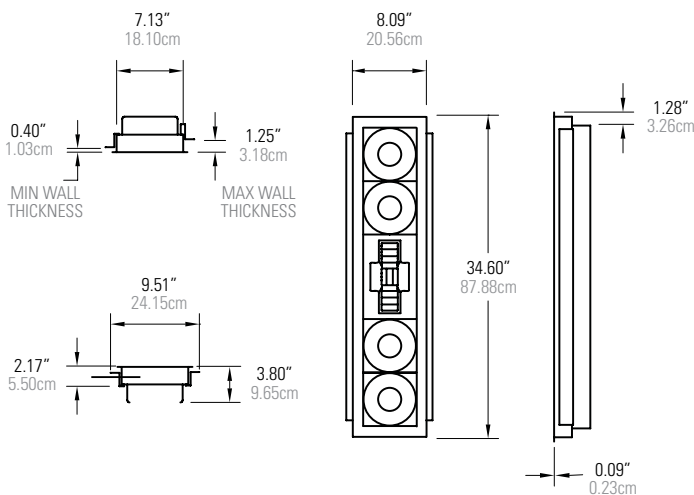

P38m, On-wall

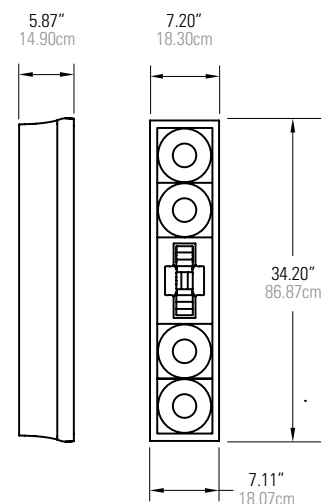

P20 Loudspeaker

Available in In-Wall, On-Wall and Freestanding versions.



P20 Loudspeaker

Compact in size, the P20 defies traditional categorization. Sharing the core technology and design elements of its larger Sage Series siblings, it is hard to believe the musical performance, realistic dynamic quality and sound pressure capability of this small loudspeaker.

The P20 can be used in in-wall (P20i), on-wall (P20m) or freestanding (P20) applications. Sharing the same driver technology, it is timbre matched and can be combined with other Sage Series in-wall, on-wall and freestanding models as desired for the specific installation. All versions are constructed entirely from aircraft grade aluminum. Slim and elegant in design, the freestanding and on-wall versions of the P20 blend nicely into a variety of décors where traditional loudspeakers might otherwise intrude excessively on the room's appearance. Their clear anodized interlocking trim bezels and matte charcoal colored cabinet convey an exquisite balance of industrial design and build quality unique among consumer loudspeakers. The narrow aspect P20i in-wall design becomes one with the wall, via its paintable grill and bezel, while its all aluminum chassis and integral back box enclosure ensure optimal and consistent performance regardless of mounting environment.

The P20 uses two of the same high operating pressure 6-inch woofers found in its larger Sage Series siblings. A groundbreaking 2-inch planar magnetic tweeter is responsible for this series' characteristic transparency, detail and instantaneous dynamics, handles the midrange and high frequencies, and extends all the way down to 650 Hz. The diaphragm is actually square, but the acoustic lens optimizes the dispersion at the highest frequencies while allowing the midrange frequencies to pass through without attenuation. The result is excellent, uniform horizontal dispersion throughout its operating range. This amazing PMD tweeter may not play as loudly as the larger ones in the other Sage models, but it will still outperform a conventional 1-inch dome tweeter, while handling almost two additional octaves of the midrange.

As with all Sage Series systems, the 7.3 channel SC-1 System Controller is the heart of the system. It provides the active crossover between bass and midrange/treble, system-specific EQ, as well as Audyssey MultEQ® XT room correction on all 17 output channels for consistent, no-compromise performance in every installation.

The P20 sonically presents itself in a room with a level of clarity, dynamic range, bass reproduction and imaging that is surprising for its size. Employing a unique planar magnetic tweeter for the majority of its output range, it is incredibly detailed and dynamic, and does not suffer from the sonic compression that plagues many conventional loudspeaker

designs. The P20 provides stunning, lifelike dynamic music reproduction that belies its slim profile and compact design.

Ideal for a multichannel system where either space constraints or the demand for a minimal visual impact solution are a priority, the P20, P20m and P20i architectural loudspeakers deliver high definition sound that is a perfect complement to high definition video, while opening up new worlds of sonic performance for your musical enjoyment.



Wisdom Audio
1572 College Parkway, Suite 164
Carson City, NV 89706
775-887-8850
fax 775-887-8820
www.wisdomaudio.com
information@wisdomaudio.com

The World's Most Advanced Architectural Loudspeakers.™

P20 Specifications

All specifications are subject to change at any time, in order to improve the product.

Frequency response	40Hz – 20kHz ± 2dB relative to the target curve
Frequency response, 30° off horizontal axis	40Hz – 15kHz ± 2dB relative to the target curve
Impedance, planar section	3 ohms
Impedance, woofer section	5 ohms
Sensitivity, planar section	87 dB / 2.83 V / 1m
Sensitivity, woofer section	87 dB / 2.83 V / 1m
Shipping weight: each P20	24 lbs. (11 kg)
each P20m	23 lbs. (10.5 kg)
each P20i	21 lbs. (9.5 kg)

P20i, In-wall

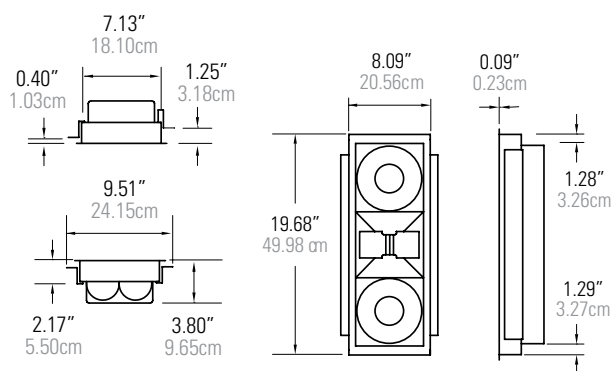

P20m, On-wall

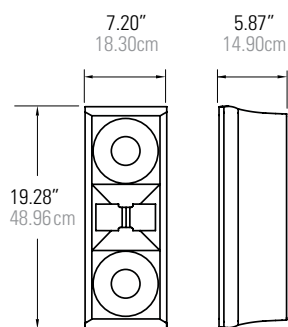

P20, Freestanding

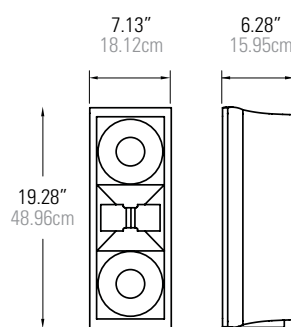

C38 Center Channel

Available in In-Wall, On-Wall and Freestanding versions.



C38 Loudspeaker

The C38 is the Sage Series flagship center channel where horizontal placement of the loudspeaker is a requirement of the installation. In rooms where a large perforated screen is being used, the L75 line source can be used as a center channel in its upright position (it is not possible to use the L75 line source horizontally).

The C38 is not a line source like the L75 and L150i, but is instead a point source loudspeaker. The vast majority of loudspeakers available in the world are point sources, meaning that they radiate their sonic energy outward in an expanding sphere, as though from a point in space.

The C38 can be used in in-wall (C38i), on-wall (C38m) or freestanding (C38) applications. Sharing the same driver technology, it is timbre matched and can be combined with other Sage Series in-wall, on-wall and freestanding models as desired for the specific installation. All versions are constructed entirely from aircraft grade aluminum. Slim and elegant in design, the freestanding and on-wall versions of the C38 blend nicely into a variety of décors where traditional loudspeakers might otherwise intrude excessively on the room's appearance. Their clear anodized interlocking trim bezels and matte charcoal colored cabinet convey an exquisite balance of industrial design and build quality unique among consumer loudspeakers. The narrow aspect C38i in-wall design becomes one with the wall, via its paintable grill and bezel, while its all aluminum chassis and integral back box enclosure ensure optimal and consistent performance regardless of mounting environment.

As you would expect, the C38 center channel is virtually identical to the P38. Though they look quite similar, the MTM tweeter is rotated 90 degrees for optimal dispersion (as is the case with the C20 compared to the P20). Four of the same high operating pressure 6-inch woofers used throughout Sage Series models mate with a unique MTM Planar Magnetic Driver array for the midrange and treble. The MTM array provides the same level of transparency, detail, and instantaneous dynamics as the 24-inch Planar Magnetic driver used in the L75 and L150i (in multiples), but is a much smaller package optimized for the space requirements associated with the P38 and other more compact Sage Series models.

As with all Sage Series systems, the 7.3 channel SC-1 System Controller is the heart of the system. It provides the active crossover between bass and midrange/treble, system-specific EQ, as well as Audyssey MultEQ® XT room correction on all 17 output channels for consistent no-compromise performance in every installation.

The C38 center channel provides no compromise performance and mates seamlessly with other Sage Series speakers. The task of the center channel can be challenging depending on the source material, often resulting in compression, distortion and lack of intelligibility. Employing planar magnetic drivers for the majority of its output, it is incredibly detailed and dynamic, and does not suffer from the sonic compression that plagues many conventional loudspeaker designs. The C38 provides stunning, lifelike dynamic music and voice reproduction that belies its slim profile and compact design. Capable of the volume and dynamics normally associated with a live performance and accompanied by excellent horizontal dispersion, the C38

measures up to the requirements of a Sage Series based multichannel system. The C38i, C38m and C38 architectural center channel loudspeakers deliver high definition sound that is a perfect complement to high definition video, while opening up new worlds of sonic performance for your musical enjoyment.



Wisdom Audio
1572 College Parkway, Suite 164
Carson City, NV 89706
775-887-8850
fax 775-887-8820
www.wisdomaudio.com
information@wisdomaudio.com

The World's Most Advanced Architectural Loudspeakers.™

C38 Specifications

All specifications are subject to change at any time, in order to improve the product.

Frequency response	40Hz – 20kHz ± 2dB relative to the target curve
Frequency response, 30° off horizontal axis	40Hz – 18kHz ± 2dB relative to the target curve
Impedance, planar section	3 ohms
Impedance, woofer section	3 ohms
Sensitivity, planar section	90 dB / 2.83 V / 1m
Sensitivity, woofer section	91 dB / 2.83 V / 1m
Shipping weight: each C38	37 lbs. (17 kg)
each C38m	39 lbs. (18 kg)
each C38i	37 lbs. (27 kg)

C38i, In-wall

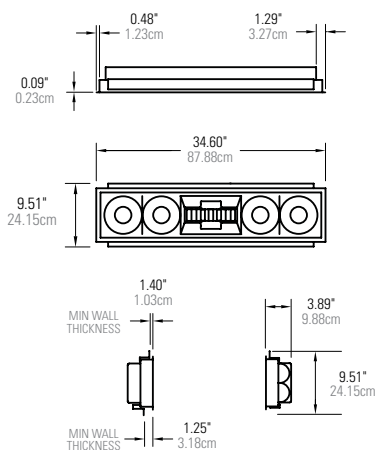

C38m, On-wall

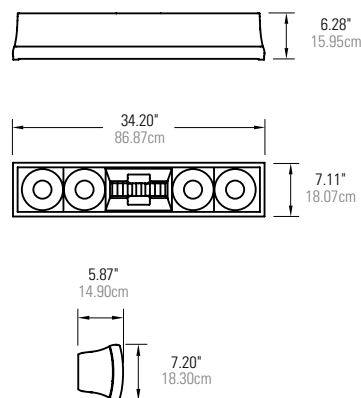

C38, Freestanding

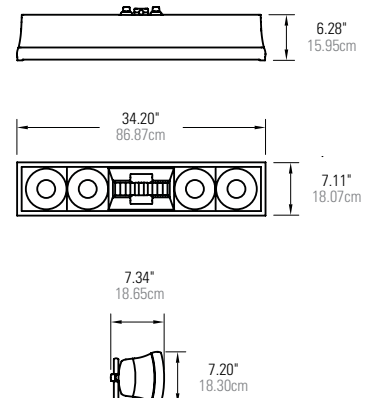

C20 Center Channel

Available in In-Wall, On-Wall and Freestanding versions.



C20 Loudspeaker

The C20 center channel is the perfect complement to a pair of P20 left and right channels, or where a center channel with a small footprint is desired. The C20 is not a line source like the L75 and L150i, but is instead a point source loudspeaker. The vast majority of loudspeakers available in the world are point sources, meaning that they radiate their sonic energy outward in an expanding sphere, as though from a point in space.

The C20 can be used in in-wall (C20i), on-wall (C20m) or freestanding (C20) applications. Sharing the same driver technology, it is timbre matched and can be combined with other Sage Series in-wall, on-wall and freestanding models as desired for the specific installation. All versions are constructed entirely from aircraft grade aluminum. Slim and elegant in design, the freestanding and on-wall versions of the C20 blend nicely into a variety of décors where traditional loudspeakers might otherwise intrude excessively on the room's appearance. Their clear anodized interlocking trim bezels and matte charcoal colored cabinet convey an exquisite balance of industrial design and build quality unique among consumer loudspeakers. The narrow aspect C20i in-wall design becomes one with the wall, via its paintable grill and bezel, while its all aluminum chassis and integral back box enclosure ensure optimal and consistent performance regardless of mounting environment.

As you would expect, the C20 center channel is virtually identical to the P20. Though they look quite similar, the groundbreaking 2-inch tweeter is rotated 90 degrees for optimal dispersion (as is the case with the MTM array of the C38 compared to the P38). The C20 uses two of the same high operating pressure 6-inch woofers found in its larger Sage Series siblings. A groundbreaking 2-inch planar magnetic tweeter is responsible for this series' characteristic transparency, detail and instantaneous dynamics, handles the midrange and high frequencies, and extends all the way down to 650 Hz. The diaphragm is actually square, but the acoustic lens optimizes the dispersion at the highest frequencies while allowing the midrange frequencies to pass through without attenuation. The result is excellent, uniform horizontal dispersion throughout its operating range. This amazing PMD tweeter may not play as loudly as the larger ones in the other Sage models, but it will still outperform a conventional 1-inch dome tweeter, while handling almost two additional octaves of the midrange.

As with all Sage Series systems, the 7.3 channel SC-1 System Controller is the heart of the system. It provides the active crossover between bass and midrange/treble, system-specific EQ, as well as Audyssey MultEQ® XT room correction on all 17 output channels for consistent no-compromise performance in every installation.

The C20 center channel provides outstanding performance and mates seamlessly with the P20 Sage Series speakers. The task of the center channel can be challenging depending on the source material, often resulting in compression, distortion and lack of intelligibility. Employing planar magnetic drivers for the majority of its output, it is incredibly detailed and dynamic, and does not suffer from the sonic compression that plagues many conventional loudspeaker designs. The C20 provides lifelike dynamic music and voice reproduction that belies its slim profile and compact design. Capable of the volume and dynamics normally associated with a live performance and accompanied by excellent horizontal dispersion, the C20 measures up to

the requirements of a Sage Series P20 based multichannel system. The C20i, C20m and C20 architectural center channel loudspeakers deliver high definition sound that is a perfect complement to high definition video, while opening up new worlds of sonic performance for your musical enjoyment.



Wisdom Audio
1572 College Parkway, Suite 164
Carson City, NV 89706
775-887-8850
fax 775-887-8820
www.wisdomaudio.com
information@wisdomaudio.com

The World's Most Advanced Architectural Loudspeakers.™

C20 Specifications

All specifications are subject to change at any time, in order to improve the product.

Frequency response	40Hz – 20kHz ± 2dB relative to the target curve
Frequency response, 30° off horizontal axis	40Hz – 15kHz ± 2dB relative to the target curve
Impedance, planar section	3 ohms
Impedance, woofer section	5 ohms
Sensitivity, planar section	87 dB / 2.83 V / 1m
Sensitivity, woofer section	87 dB / 2.83 V / 1m
Shipping weight: <i>each C20</i>	24 lbs. (11 kg)
<i>each C20m</i>	23 lbs. (10 kg)
<i>each C20i</i>	21 lbs. (9.5 kg)

C20i, In-wall

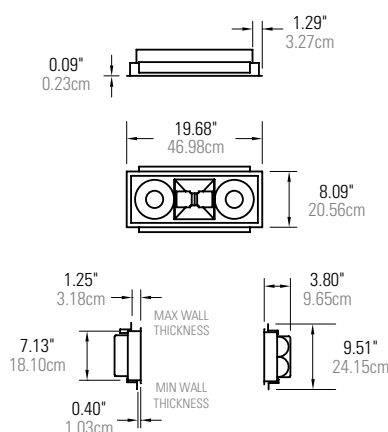

C20m, On-wall

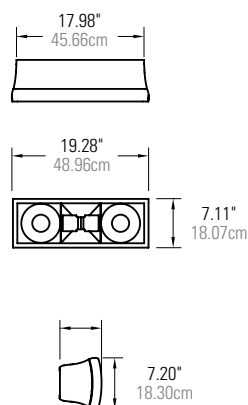

C20, Freestanding

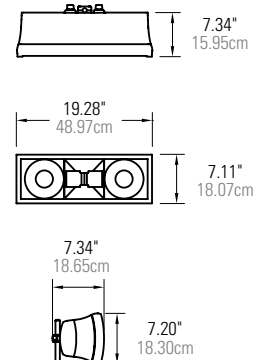

S90i Subwoofer

Available in In-Wall version.



S90i Subwoofer

The S90i transcends the previous limitations of in-wall subwoofer designs and ideally complements our Sage Series planar magnetic loudspeaker systems. Finally, there is a high-end subwoofer solution for customers who desire no-compromise performance but prefer the aesthetic benefits of custom installed, hidden loudspeakers.

The Sage Series S90i in-wall/in-ceiling subwoofer's highly efficient design yields fast, dynamic, articulate results with accurate timbre. Ideally, a pair of S90i subwoofers can be mated to a single Sage Series SA-1 System Amplifier which can drive two S90i units via its single input, with more than 500 watts available for each subwoofer. However, any of the Sage Series amplifiers can be used with the S90i. Also, when used in a Sage Series speaker system, Audyssey™ room correction is provided via the SC-1 System Controller, further optimizing the S90i in-room response*.

We examined all types of transducer and cabinet loading options to determine a design that would complement the extraordinary dynamics and low distortion of our in-wall planar magnetic systems. The regenerative line design of the S90i proved to be our best option for ensuring a high performance, no-compromise low frequency solution when installed in a stud bay, ceiling, or floor.

The S90i's novel dual woofer, regenerative line design takes full advantage of stud bay space to achieve high-end performance. The S90i is constructed of a wood cabinet measuring 90-inches H x 14-inches W x 5.5-inches D that occupies a full 2 x 6 stud bay and can be mounted in-ceiling, in-wall, under risers, in closets, and in floors. This S90i is a rare example of a custom-centric design that offers competitive results versus the finest freestanding options. The S90i's superb performance characteristics, which include flat response to 20 Hz with usable in-room energy down to 17 Hz, and outstanding dynamic capability and accurate timbre reproduction, derive from a design that would be too large to be practical in a freestanding version for typical domestic environments. Its size makes it well suited to being custom-installed and thereby hidden behind its small paintable grill and bezel.

The unique solution offered by the S90i complements not only Sage Series systems, but any system in which the customer demands an in-wall solution with no compromise performance. Previously, in-wall subwoofers presented a significant performance compromise. The S90i has set the bar higher, offering a level of performance among in-wall subwoofers that was previously unavailable.



**The S90i must be used in conjunction with a Sage Series SC-1 System Controller.*



Wisdom Audio
1572 College Parkway, Suite 164
Carson City, NV 89706
775-887-8850
fax 775-887-8820
www.wisdomaudio.com
information@wisdomaudio.com

The World's Most Advanced Architectural Loudspeakers.™

S90i Specifications

All specifications are subject to change at any time, in order to improve the product.

Frequency response	20Hz – 80 Hz ± 2dB relative to the target curve
Impedance	4 ohms
Sensitivity	93 dB / 2.83V / 1m
Power handling, peak	1000w
Maximum SPL	123dB / 20Hz / 1m
Shipping weight	65 lbs. (30 kg)

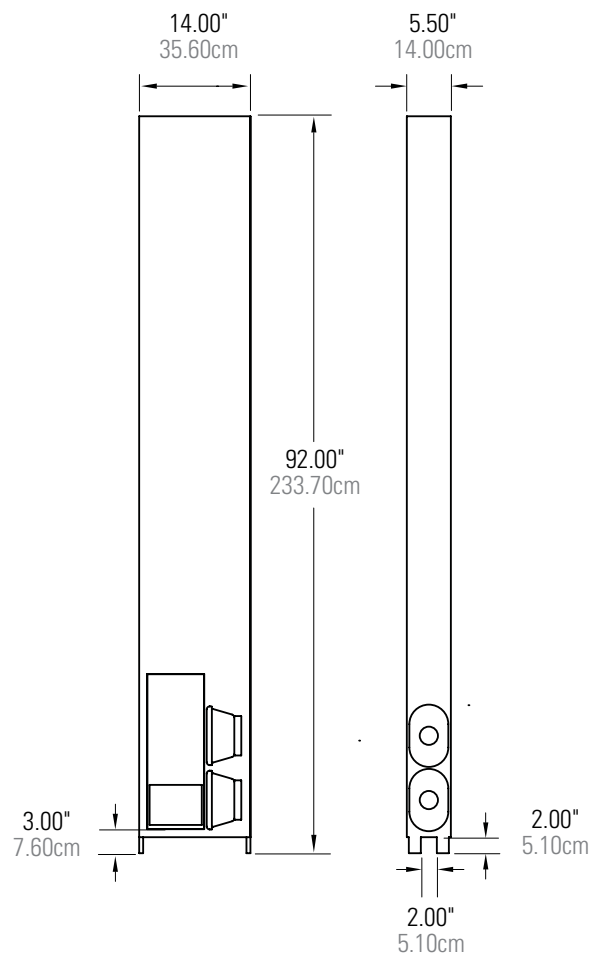

SCS Subwoofer

Available in Freestanding version.



SCS Subwoofer

The SCS is nicknamed the “Suitcase Sub” because of its uncommon form factor and size of 7-inches W x 22.5-inches H x 37-inches D. When installation of the Sage Series S90i in-wall subwoofer is not practical, the compact size and aspect ratio of the SCS allows it to be placed in areas where other in-room subwoofers will not fit, offering customers a unique freestanding subwoofer option – one that can actually be hidden.

We examined all types of transducer and cabinet loading options to determine a design that would complement the extraordinary dynamics and low distortion of our planar magnetic systems. The Regenerative Transmission Line™ design of the S90i proved to be the ideal option for ensuring a high performance, no-compromise low frequency solution when installed in a stud bay, ceiling, or floor. And, the free-standing SCS uses this same Regenerative Transmission Line design to deliver results that simply belie its diminutive size.

The SCS is powered by a 400-watt internal amplifier and is capable of 120 dB @ 25 Hz. The dual 5-inch x 7.5-inch woofer design yields an equivalent active cone area of 13 inches and is taken directly from the larger Sage Series S90i in-wall subwoofer.

The unique ‘multi-port’ design allows for flexibility in how the SCS’ output is ported into the room. The uncommon shape of the SCS creates opportunities for installation in places where a cube subwoofer would not fit or be effective. In taking full advantage of the seven-inch dimension, the SCS can be placed under or behind furniture, such as a sofa or cabinets, so as to remain out of sight, and with the port configured to any of three sides. Never before has a freestanding subwoofer offered such unprecedented installation flexibility.

The Sage Series SCS subwoofer’s highly efficient and compact design yields fast, dynamic, articulate results with accurate timbre. When used in a Sage Series speaker system, Audyssey™ room correction is provided via the SC-1 System Controller, and further optimizes the SCS’s in-room response.

However, unlike the S90i, which is required to be used in conjunction with the Sage Series SC-1 System Controller, the SCS’s integral crossover and gain control allow it to be used with a wide range of systems. Instead of living with the compromise of a conspicuous “bass cube” subwoofer, the SCS can be considered for use with any speaker system where the deepest bass should be heard, but not seen. With its ability to be placed under or behind furniture, such as sofas and beds, or hidden inside theater risers or entertainment rack kick panels, the SCS makes most subwoofers appear cumbersome and inflexible.

The SCS strikes the perfect balance when a subwoofer must be placed within a room – no more compromises required.



Wisdom Audio
 1572 College Parkway, Suite 164
 Carson City, NV 89706
 775-887-8850
 fax 775-887-8820
 www.wisdomaudio.com
 information@wisdomaudio.com

The World's Most Advanced Architectural Loudspeakers.™

SCS Specifications

All specifications are subject to change at any time, in order to improve the product.

Frequency response	20Hz – 80 Hz ± 3dB relative to the target curve
Maximum output	120 db @ 25 Hz
Rated power	400w
Power handling, peak	575W (+/- 5%) at full power
Mains voltage	100 / 120V, or 230 / 240V
Shipping weight	72 lbs. (33 kg)

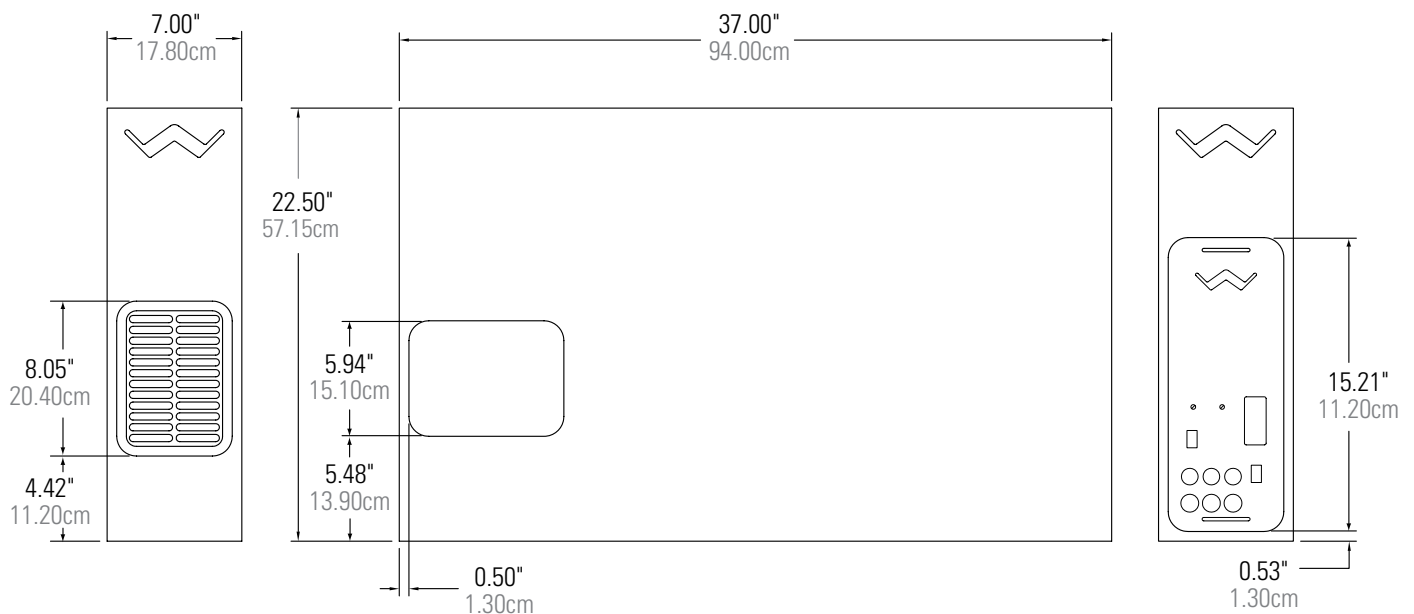

Uni-Grip® In-Wall Mount



Uni-Grip® In-Wall Mount

Most in-wall loudspeakers clamp themselves to the wall using relatively small “dogs” that pinch the wall material (typically plaster or sheetrock). These dogs work well enough for the small, light loudspeakers typically used for background music. However, a more robust loudspeaker that reproduces the full range of modern music and film soundtracks requires more robust attachment... much more, in fact.

Wisdom Audio created an innovative Uni-Grip system that clamps the speaker to the wall continuously along the length of the loudspeaker. Having many times the clamping area of small pinch dogs, an installed Uni-Grip loudspeaker actually strengthens the wall, making it more rigid than it was prior to the loudspeaker’s opening being cut. Uni-Grip thereby minimizes spurious resonances that could seriously degrade sonic performance.

Increased clamping area also means that the clamping pressure at any point along the perimeter need not be as high, protecting both the wall’s integrity and delicate wall treatments like premium wallpaper or custom paint finishes.

Best of all, the Wisdom Audio dealer can install the frame and keep the in-wall speaker itself safely in their possession until after the other installation work in the room is complete. The speaker can then be installed easily in the frame before calibration of the Sage Series system.

The Uni-Grip In-Wall Mount is used for the majority of Sage Series in-wall loudspeakers.



Each set of drivers has its own dedicated aircraft grade aluminum rear enclosure (back-box) to ensure optimal performance of in-wall models regardless of the acoustic environment presented by the home's walls.



Wisdom Audio
 1572 College Parkway, Suite 164
 Carson City, NV 89706
 775-887-8850
 fax 775-887-8820
www.wisdomaudio.com
information@wisdomaudio.com

The World's Most Advanced Architectural Loudspeakers.™

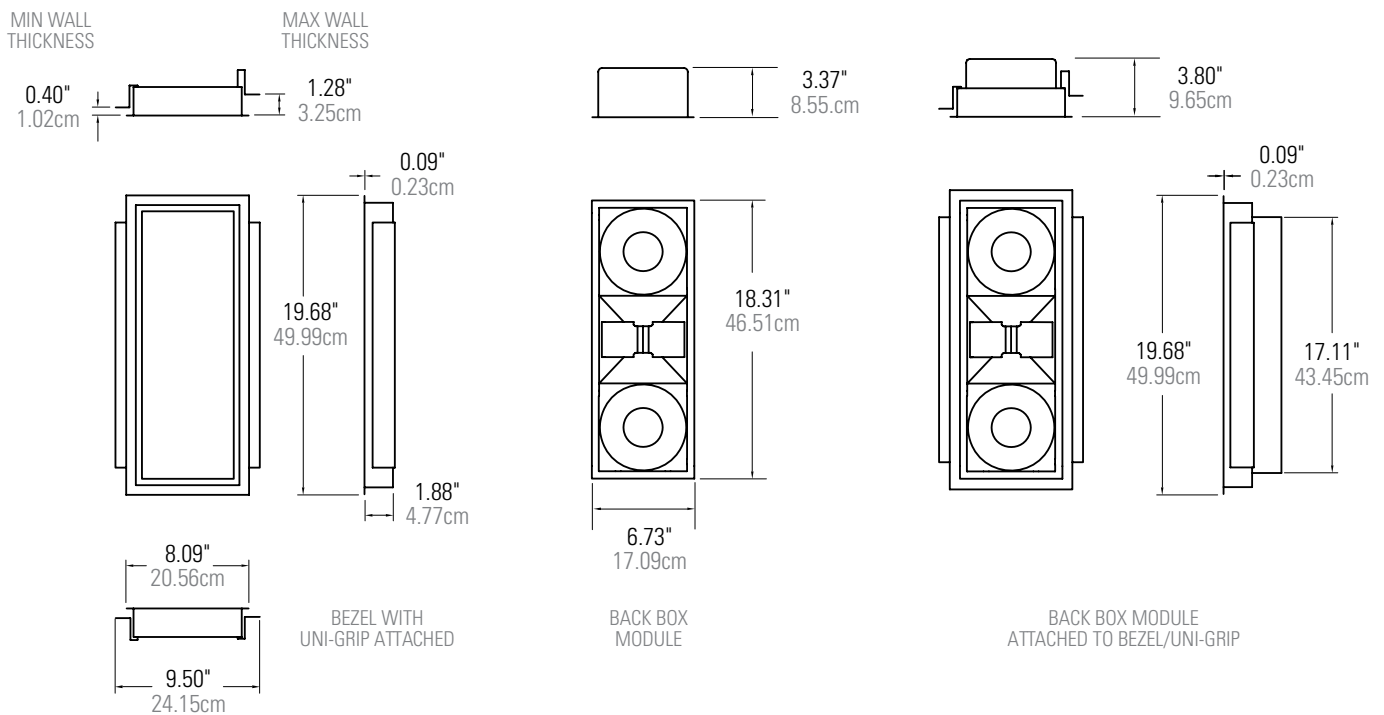

SC-1 System Controller



SC-1 System Controller

Wisdom Audio's SC-1 System Controller incorporates an electronic crossover and acoustic room correction that incorporates Audyssey MultEQ® XT technology. It also includes selectable, RS-232 operable memory settings for optimized performance in varied acoustic settings for music and film environments. A PC-based installation application allows a professional installer to configure the SC-1 for the particular complement of Sage Series speakers used in a given installation.

A good loudspeaker is designed to deliver sound with little distortion and coloration. But when even great speakers are placed in a room, things change. Walls, furniture, and other objects reflect and absorb the sound from your speakers, creating complex distortions specific to your room, which could not have been predicted by the loudspeaker designer.

Advanced Room Correction

Audyssey MultEQ XT is a room equalization solution that calibrates any audio system so that it can achieve optimum performance for every listener in a large listening area. MultEQ XT captures acoustical information at multiple locations throughout a listening area in both the time and frequency domains. It uses a sophisticated clustering algorithm to combine this information so that acoustical problems are accurately analyzed. Based on these measurements, MultEQ XT calculates an equalization solution that corrects for both time and frequency response problems in the listening area and also performs a fully automated surround system setup.

The result is clear, well-balanced sound for every listener. Wisdom Audio licensed the most sophisticated form of this technology for use in our systems, and worked closely with Audyssey™ to ensure that you get all the performance you deserve.

Multiple Setup Memories

We then went further and provided support for recalling up to three complete and independent setup calibrations, any of which can be selected as needed. While a single setup is all that is necessary, having the ability to recall any of multiple setups can solve some otherwise difficult situations. For example, you might want to have selectable setups for different room conditions (e.g., drapes open vs. closed) or slightly different target curves (e.g., music vs. gaming).

Bi- or Tri-amplification

People who have wanted to extract the highest performance from their systems have known for a long time that driving each section of the speaker directly and separately yields the finest results. Of course, this requires having a dedicated, active crossover to divide the frequency range appropriately before the power amplifiers, so that they can then drive the speakers directly.

Bi-amplification makes use of two channels of amplification to drive different portions of a single channel. The most common instance of "bi-amping" today is in home theater applications, wherein a dedicated subwoofer handles the deepest bass, while the remaining audible range is handled by the various front and surround speakers. But you can also bi-amplify a full range loudspeaker, driving the woofer separately from the drivers that handle the midrange and treble frequencies.



Logically, you can combine these two approaches, and the result is “triamplication.” A “tri-amped” system uses separate amplification for three audible ranges. In our case, the three ranges are:

- * Deepest bass (one or more subwoofers)
- * Mid-bass (the woofers in the front and surround speakers)
- * Midrange and treble (the planar magnetic panels)

Since each channel of the amplifier is delivering current into its load only over a limited range of frequencies, several forms of distortion are reduced as compared to each channel handling the full range of musical information.

The SC-1 supports up to a “7.3 channel” system, meaning that up to seven main speakers can be supported (all of which are biampified), plus up to three independent subwoofer channels. All of these outputs benefit from room correction, described above.

System-Specific EQ

Wisdom Audio speakers deliver extraordinary performance from slim, elegant enclosures. However, we cannot cheat the rules of physics. Delivering powerful bass from such small enclosures places unusual demands on both the woofers and the amplifiers used to drive them.

Specifically, equalization is used to compensate for the unusually small enclosure volume behind the woofer. This approach is used in almost all dedicated subwoofers today, and we use it in our full range speakers. Doing so allows us to achieve the bass performance usually associated much larger speakers, but in elegant enclosures that support modern lifestyle choices.



Wisdom Audio
1572 College Parkway, Suite 164
Carson City, NV 89706
775-887-8850
fax 775-887-8820
www.wisdomaudio.com
information@wisdomaudio.com

The World's Most Advanced Architectural Loudspeakers.™

SC-1 Specifications

All specifications are subject to change at any time, in order to improve the product.

Signal to Noise ratio	-110dB (ref 2.5V rms A-wtd.)
Input impedance	25kΩ (balanced)
Output impedance	50Ω
Maximum output voltage	2.5V rms
Maximum input voltage	2.5V rms
Power consumption	33W
Thermal load	2 BTU/minute
DC trigger input sensitivity	3-20V @ 10 mA
DC trigger output signal	12V @ 100 mA
Mains voltage ranges	100-120V or 200-240V
Shipping weight	34 lbs. (15.4 kg)

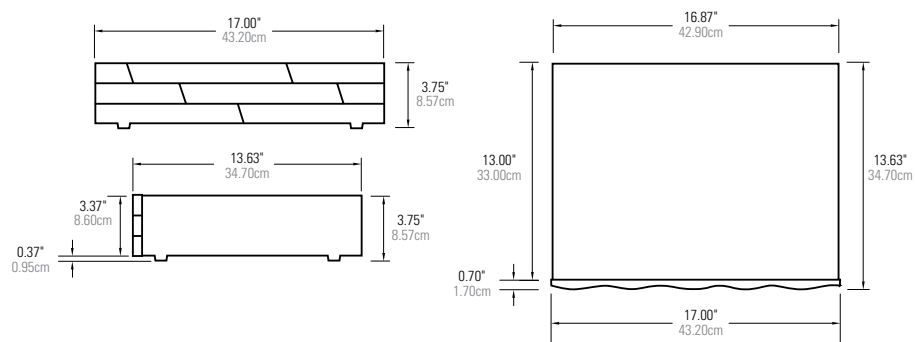

SA Series System Amplifiers



Photo is representative of all units and is a SA-3

SA Series System Amplifiers

The Wisdom Audio amplifier/speaker system is designed to take advantage of a fact that has hitherto been understood only by a relatively small number of audiophiles: speakers sound better when they are driven directly by dedicated, high quality amplifiers.

You might think that all speakers are configured to be used in that manner. After all, you connected your receiver or amplifier directly to the loudspeaker cabinet, using high quality wire. But in almost all cases, that connection led to a passive crossover network within the speaker cabinet, made up of resistors, capacitors and coils of wire called inductors. The passive crossover had the job of splitting up the signal to the woofer, midrange, and tweeter inside the cabinet. By

design, it created a complex, reactive circuit between the amplifier and the drivers that actually make the music.

The Wisdom Audio approach does not suffer from this compromise. The SC-1 System Controller includes an active (not passive) crossover that divides the music signal while still at a preamplifier level. It can do so with far greater accuracy and consistency than can passive components of any quality in a speaker box, with their inevitable high current production tolerances. The separate signals at the output of the SC-1 are then routed to dedicated amplifiers which need work with only a portion of the audible range.

This approach is called "bi-amplification" since each speaker is actually using two channels of amplification. It provides several important benefits: greater excitement due to improved dynamics; improved detail and intelligibility thanks to lower distortion; improved clarity and control.

Wisdom Audio systems take this multiple-amp-per-speaker idea even further. When you add one or more dedicated subwoofers that handle only the deepest bass, the system is "tri-amplified." The benefits of enormous power reserves are fairly obvious: freedom from any audible strain, greater dynamic impact, and the ability to hear music and movie soundtracks at their intended volume without worrying about whether the system can handle it.

However, the traditional methods for achieving this required level of performance involve bulky, heavy designs that generate a great deal of heat. When you multiply the number of channels required for a modern home theater application times two (for bi-amplification), and add in one or more dedicated subwoofers, suddenly you have need for smaller, more efficient amplifier designs. While many contemporary amplifiers waste 50% or more of the power they pull from the wall as heat, our SA series amplifiers run at approximately 90% efficiency. As a result, more power is available for the loudspeaker, and less is wasted as heat in your room.

SA-1



SA-2



SA-3



The high efficiency of the SA series design also means that the amplifiers can be placed in close proximity to each other, as in an equipment rack, without undue overheating. Of course, care must be taken to account for the heat generated by other components in the rack; but the Wisdom Audio SA series amplifiers will not greatly contribute to the thermal management challenges of your system.

All SA series amplifiers are identical in size and are rated at 500 watts per channel, available in 3 channel, 2 channel and single input, two channel output configurations.



Wisdom Audio
1572 College Parkway, Suite 164
Carson City, NV 89706
775-887-8850
fax 775-887-8820
www.wisdomaudio.com
information@wisdomaudio.com

The World's Most Advanced Architectural Loudspeakers.™

SA Series Amplifier Specifications (applies to all models)

All specifications are subject to change at any time, in order to improve the product.

Rated power output per channel	500 w/ch continuous rms power @ 4Ω above power ratings from 20 Hz–20 kHz at <0.5% THD
Peak output current	> 30 amps
Voltage gain	31 dB
Input sensitivity	1.2V for full output
Input impedance	25 kΩ (balanced)
Polarity	Non-inverting, Pin 2 positive
Signal to noise ratio (main outputs)	–103 dB (ref 1V rms, A-wtd.)
Output impedance	less than 0.05Ω from 20–20,000 Hz
Thermal load	7 BTU/minute or less
Mains voltage	100V, 120V, or 230/240V determined by the needs of country for which the unit was manufactured; cannot be reset by dealer or user
Shipping weight	40 lbs. (19 kg)
Power consumption, SA-3 SA-1, SA-2 all 3 models	1870W (±5%) at full power, all channels driven 1255W (±5%) at full power, all channels driven 10W (±5%) at idle and 2W (±5%) in standby

Photo is representative of all units and is a SA-3

